

**SECTION BT**

GI

MA

EM

LC

**CONTENTS**

EC

<b>PRECAUTIONS AND PREPARATION</b> .....2	⑫ Rear door parting seal..... 24	
Precautions .....2	⑬ Rear door corner molding ..... 24	
Supplemental Restraint System (SRS)	⑭ Door outside molding ..... 24	FE
“AIR BAG” .....2	⑮ Sunroof lid weatherstrip..... 25	
Clip and Fastener .....2	⑯ Side guard molding ..... 25	CL
<b>BODY END</b> .....5	⑰ Trunk lid weatherstrip ..... 25	
Body Front End.....5	⑱ Trunk lid finisher ..... 25	
Body Rear End and Opener..... 8	⑲ Rear combination lamp ..... 26	MT
<b>DOOR</b> ..... 11	⑳ Fender and center mudguard..... 27	
Front Door..... 11	㉑ Rear air spoiler and high-mounted	
Rear Door ..... 12	stop lamp ..... 27	AT
<b>INSTRUMENT PANEL</b> ..... 13	<b>SEAT</b> ..... 28	
<b>INTERIOR TRIM</b> ..... 16	Front Seat ..... 28	FA
Side and Floor Trim ..... 16	Rear Seat..... 29	
Door Trim ..... 18	<b>SUNROOF</b> ..... 30	
Roof Trim ..... 20	Removal ..... 31	RA
Trunk Room Trim ..... 21	Trouble Diagnoses ..... 32	
<b>EXTERIOR</b> ..... 22	Drain Hoses ..... 33	
① Hood front seal ..... 22	Weatherstrip..... 33	BR
② ③ Cowl top seal and cowl top grille..... 22	Link And Wire Assembly..... 33	
④ Windshield side molding..... 22	Adjustment ..... 34	
⑤ Windshield upper molding ..... 23	<b>WINDSHIELD AND WINDOWS</b> ..... 35	ST
⑥ Drip weatherstrip ..... 23	Windshield and Rear Window ..... 36	
⑦ Body side welt ..... 23	Quarter Window ..... 37	RS
⑧ Door weatherstrip ..... 23	<b>MIRROR</b> ..... 38	
⑨ Rear window upper molding and side	Door Mirror..... 38	
molding ..... 23	<b>BODY ALIGNMENT</b> ..... 39	<b>BT</b>
⑩ Rear window lower molding ..... 23	Engine Compartment..... 39	
⑪ Door sash molding ..... 24	Underbody..... 41	HA

★ For seat belt, refer to MA and RS section.

★ For wiring diagrams of body electrical systems, refer to EL section.

EL

IDX

# PRECAUTIONS AND PREPARATION

## Precautions

- When removing or installing various parts, place a cloth or padding onto the vehicle body to prevent scratches.
- Handle trim, molding, instruments, grille, etc. carefully during removing or installing. Be careful not to soil or damage them.
- Apply sealing compound where necessary when installing parts.
- When applying sealing compound, be careful that the sealing compound does not protrude from parts.
- When replacing any metal parts (for example, body outer panel, members, etc.), be sure to take rust prevention measures.

## Supplemental Restraint System (SRS) “AIR BAG”



The Supplemental Restraint System “AIR BAG”, used along with a seat belt, helps to reduce the risk or severity of injury to the driver and front passenger in a frontal collision. The Supplemental Restraint System consists of air bag modules (located in the center of the steering wheel and on the instrument panel on the passenger side), a diagnosis sensor unit, warning lamp, wiring harness and spiral cable. Information necessary to service the system safely is included in the **RS section** of this Service Manual.

### WARNING:

- To avoid rendering the SRS inoperative, which could increase the risk of personal injury or death in the event of a collision which would result in air bag inflation, all maintenance should be performed by an authorized NISSAN dealer.
- Improper maintenance, including incorrect removal and installation of the SRS, can lead to personal injury caused by unintentional activation of the system.
- Do not use electrical test equipment on any circuit related to the SRS unless instructed to in this Service Manual. SRS wiring harnesses are covered with yellow insulation either just before the harness connectors or on the complete harness, for easy identification.



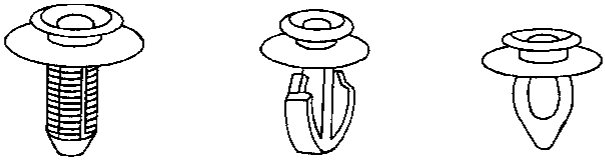
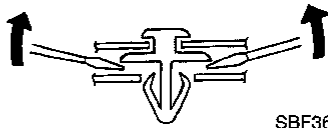

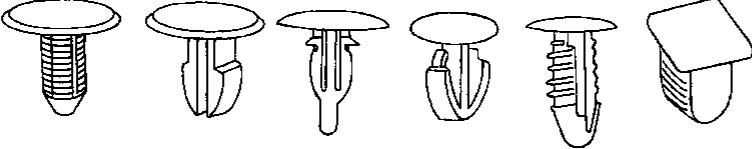
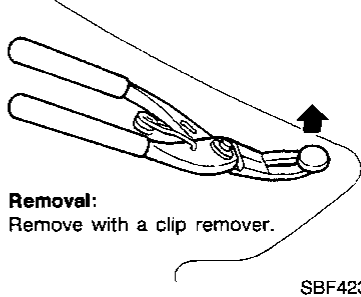

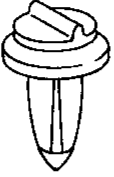
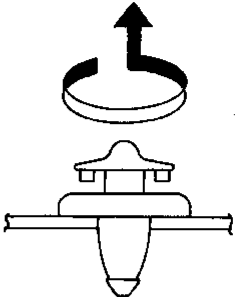

## Clip and Fastener

- Clips and fasteners in BT section correspond to the following numbers and symbols.
- Replace any clips and/or fasteners which are damaged during removal or installation.

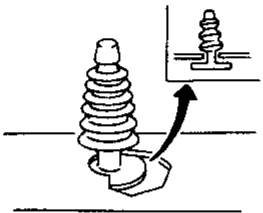
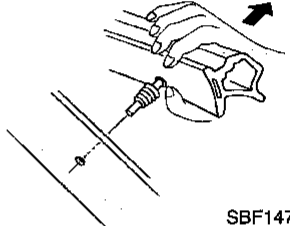
Symbol No.	Shapes	Removal & Installation
 C101	 SBF302H	<p><b>Removal:</b> Remove by bending up with flat-bladed screwdrivers or clip remover.</p>  SBF367BA
 C103	 SBT095	<p><b>Removal:</b> Remove with a clip remover.</p>  SBF423H

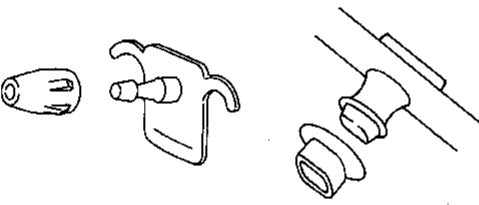
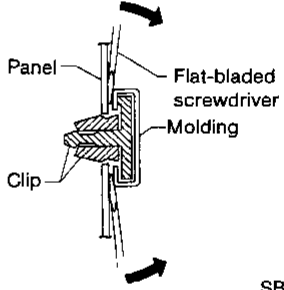
# PRECAUTIONS AND PREPARATION

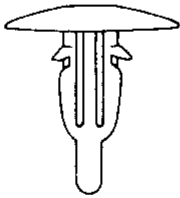
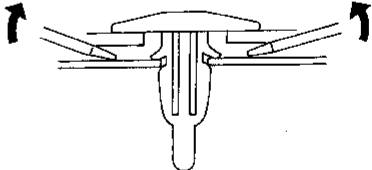
## Clip and Fastener (Cont'd)

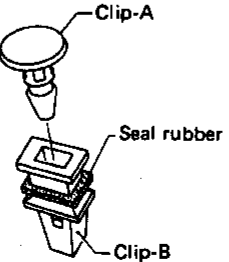
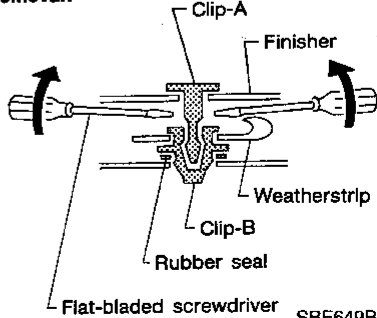
Symbol No.	Shapes	Removal & Installation
		 <p style="text-align: right;">MBF519B <span style="float: right;">MBF520B</span></p>
		<p><b>Removal:</b></p>  <p style="text-align: right;">SBF104B <span style="float: right;">SBF147B</span></p>
		 <p style="text-align: right;">SBF411H <span style="float: right;">SBF767B</span></p>
		<p><b>Removal:</b> Remove by bending up with a flat-bladed screwdriver or pliers.</p>  <p style="text-align: right;">SBF174D <span style="float: right;">SBF175DA</span></p>
		<p><b>Removal:</b></p>  <p style="text-align: right;">SBF648B <span style="float: right;">SBF649B</span></p>

GI

MA

EM

LC

EC

FE

CL

MT

AT

FA

RA

BR

ST

RS

BT







HA

EL

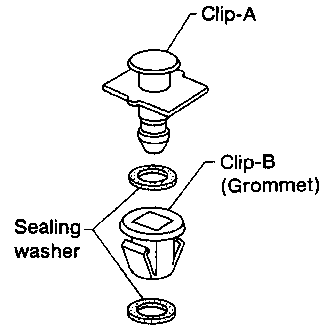
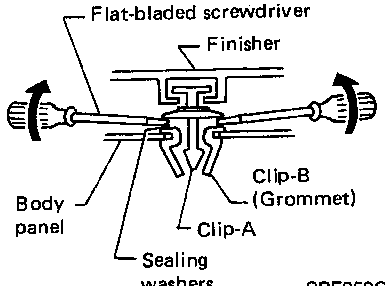
IDX

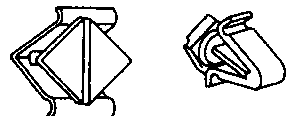
# PRECAUTIONS AND PREPARATION

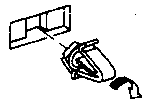
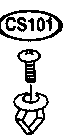
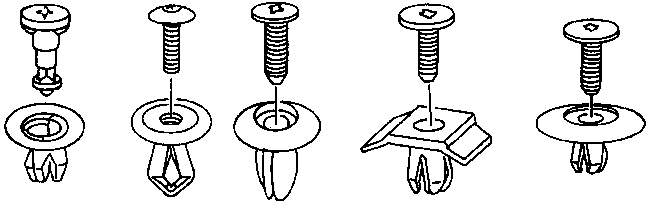
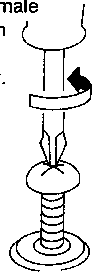
## Clip and Fastener (Cont'd)

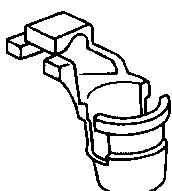
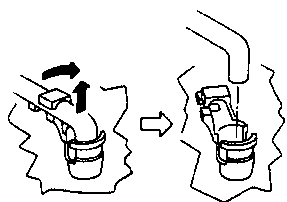
Symbol No.	Shapes	Removal & Installation
	 <p style="text-align: right;">SBF151D</p>	<p><b>Removal:</b></p>  <p style="text-align: right;">SBF259G</p>
	 <p style="text-align: right;">SBF145B</p>	<p><b>Removal:</b></p>  <p>Rotate 45° to remove.</p> <hr/> <p><b>Installation:</b></p>  <p style="text-align: right;">SBF085B</p>
	 <p style="text-align: right;">SBF078B</p>	<p><b>Removal:</b></p> <ol style="list-style-type: none"> <li>1. Screw out with a Phillips screwdriver.</li> <li>2. Remove female portion with flat-bladed screwdriver.</li> </ol>  <p style="text-align: right;">SBF992G</p>
	 <p style="text-align: right;">SBF768B</p>	<p><b>Removal:</b></p> <p>Holder portion of clip must be spread out to remove rod.</p>  <p style="text-align: right;">SBF770B</p>

# BODY END

## Body Front End

- When removing or installing hood, place a cloth or other padding on front fender panels and cowl top. This prevents vehicle body from being scratched. GI
- Bumper fascia is made of plastic. Do not use excessive force and be sure to keep oil away from it.
- Hood adjustment: Adjust at hinge portion. **E**
- Hood lock adjustment: After adjusting, check hood lock control operation. Apply a coat of grease to hood lock engaging mechanism. MA
- Hood opener: Do not attempt to bend cable forcibly. Doing so increases effort required to unlock hood. EM

### Removal — Front bumper assembly

- ① Remove screws securing left and right front fog lamps, and remove the lamps. LC
- ② Remove clips **CG101**, then remove the front grille. **A**
- ③ Remove clips **CS101** and screws located on front side of fender protector at wheel opening. EC
- ④ Remove two screws and two clips **CS101** securing upper side of front bumper fascia.
- ⑤ Remove seven screws, seven clips and air deflector. FE
- ⑥ Remove two screws securing lower side of front bumper fascia.
- ⑦ Pull out front bumper fascia and energy absorber.
- ⑧ Remove four bolts securing bumper reinforcement, then remove bumper reinforcement.
- ⑨ Remove four bolts and clip **CS101** securing front bumper side stays. CL
- ⑩ Remove front bumper side stays. Remove front bumper side stays. MT

AT

FA

RA

BR

ST

RS

**BT**

HA

EL

IDX

# BODY END

## Body Front End (Cont'd)

### SEC. 620 • 623 • 630

#### Hood lock adjustment

- Adjust hood so that hood primary lock meshes at a position 1 to 1,5 mm (0.039 to 0.059 in) lower than fender.
- After hood lock adjustment, adjust bumper rubber.
- When securing hood lock, ensure that it does not tilt. Striker must be positioned at the center of hood primary lock.
- After adjustment, ensure that hood primary and secondary lock operate properly.

#### Hood lock secondary latch hooking length

More than 5.0 mm (0.197 in)

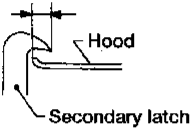

#### Bumper rubber adjustment

- Adjust so that hood is aligned with fender. At that time deflection is approximately 2 mm (0.08 in). [Bumper rubber free height is approximately 13 mm (0.51 in)]

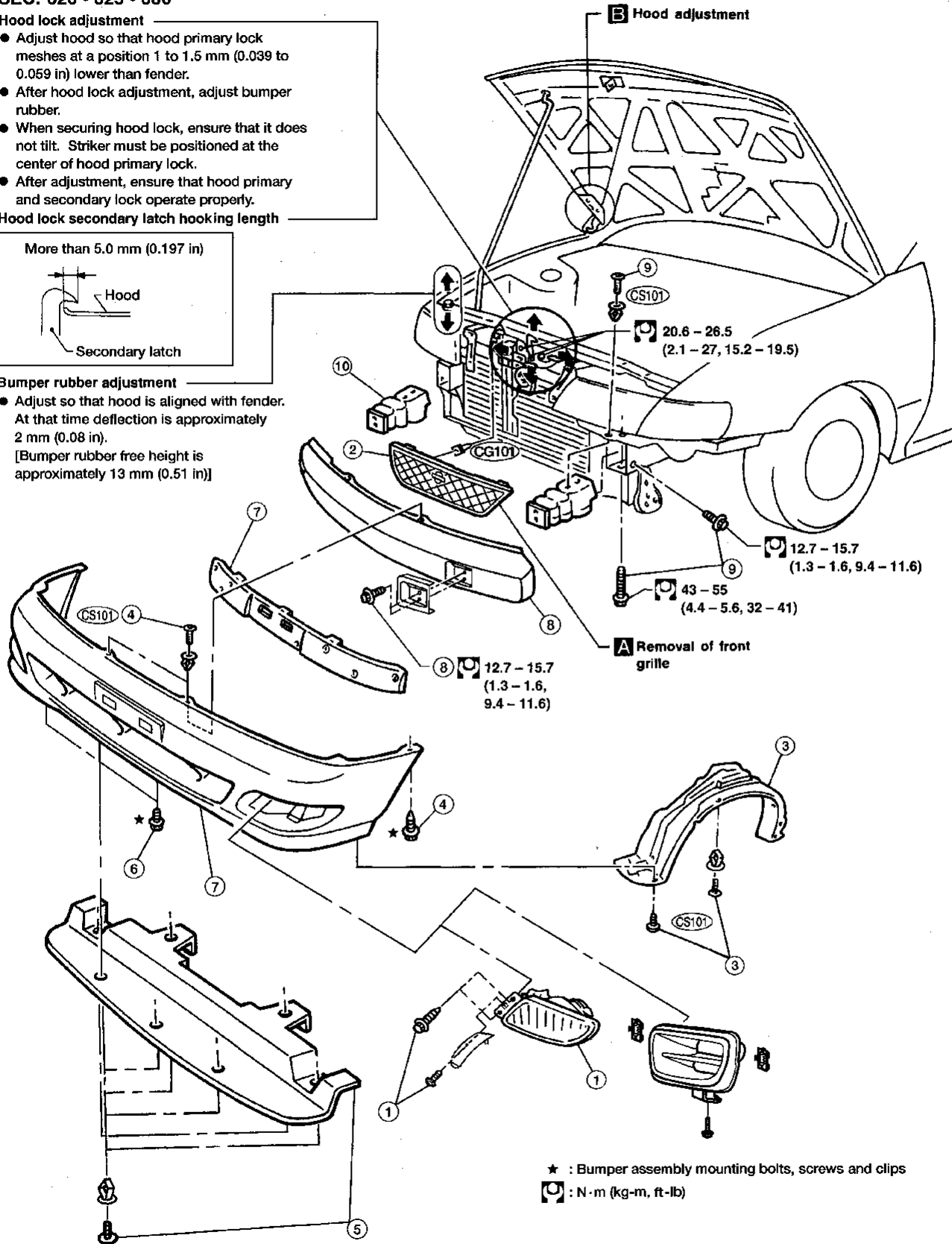

★ : Bumper assembly mounting bolts, screws and clips

⌘ : N-m (kg-m, ft-lb)

# BODY END

## Body Front End (Cont'd)

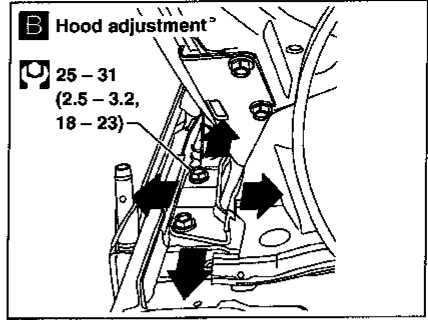
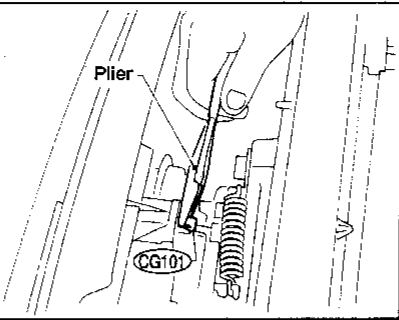
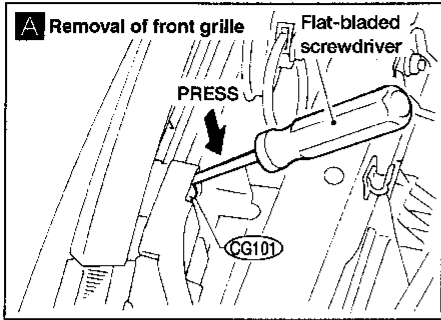

: N · m (kg-m, ft-lb)

ABT336

- GI
- MA
- EM
- LC
- EC
- FE
- CL
- MT
- AT
- FA
- RA
- BR
- ST
- RS
- BT**
- HA
- EL
- IDX

### Body Rear End and Opener

- When removing or installing trunk lid, place a cloth or other padding on rear fender panels. This prevents vehicle body from being scratched.
- Bumper fascia is made of plastic. Do not use excessive force and be sure to keep oil away from it.
- Trunk lid adjustment: Adjust at hinge-trunk lid portion for proper trunk lid fit.
- Trunk lid lock system adjustment: Adjust striker so that it is in the center of the lock. After adjustment, check trunk lid lock operation.
- Opener cable: Do not attempt to bend cable using excessive force.
- After installation, make sure that trunk lid and fuel filler lid open smoothly.

### REMOVAL — Rear bumper assembly

- ① Remove four screws securing mudguards, then remove mudguards.
- ② Remove four bolts and one clip **CS101** from lower side of rear bumper fascia.
- ③ Remove two screws from each fender side.
- ④ Remove four clips **CS101** from upper side of rear bumper fascia.
- ⑤ Pull out rear bumper fascia.
- ⑥ Remove eight nuts securing bumper reinforcement, then remove bumper reinforcement.
- ⑦ Remove four bolts securing bumper side stays, then remove bumper side stays.



# BODY END

## Body Rear End and Opener (Cont'd)

SEC. 843 • 850

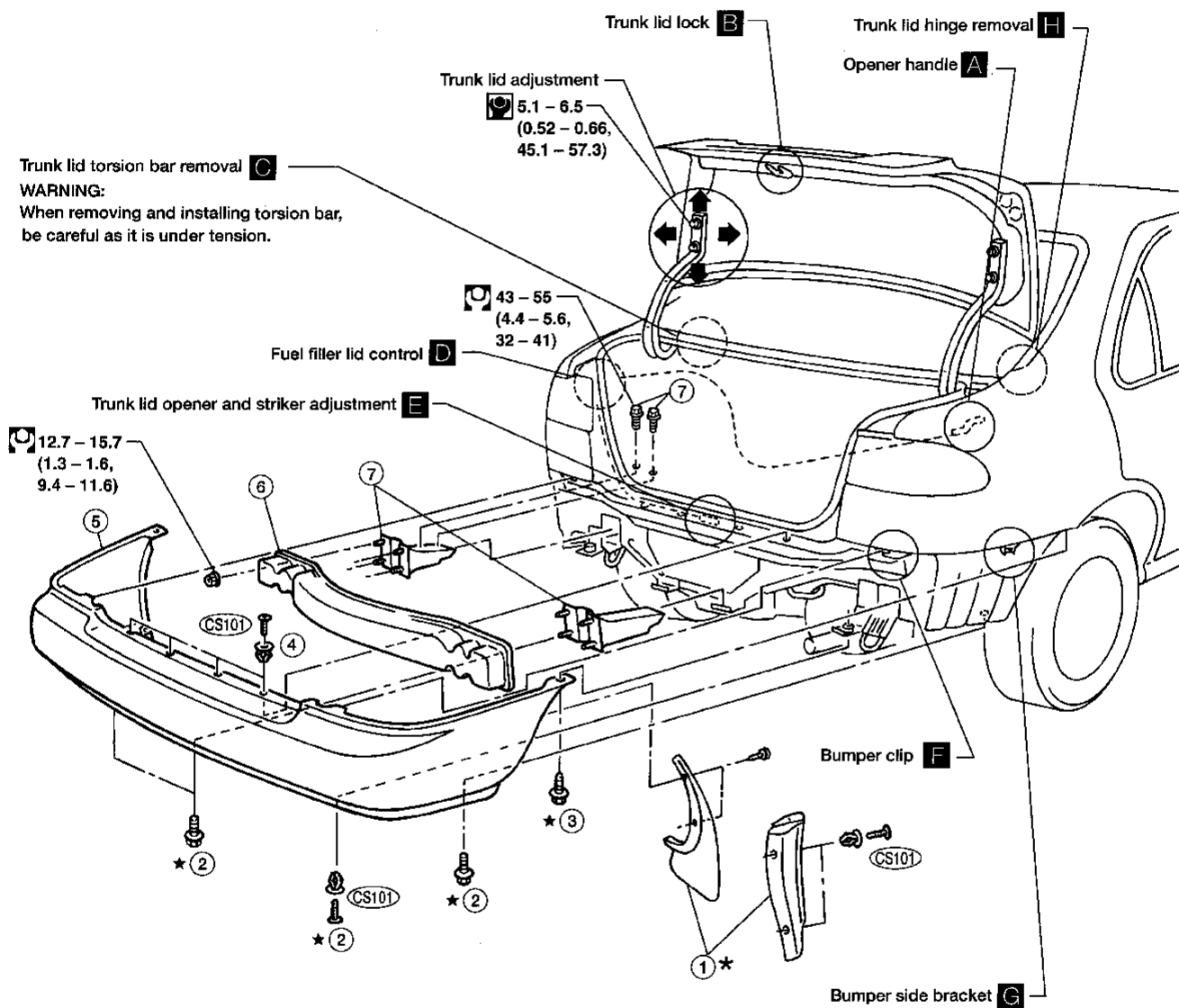

- ★ : Canadian models only
- ★ : Bumper assembly mounting bolts, screws and clips.
- : N·m (kg-m, in-lb)
- : N·m (kg-m, ft-lb)

GI  
 MA  
 EM  
 LC  
 EC  
 FE  
 CL  
 MT  
 AT  
 FA  
 RA  
 BR  
 ST  
 RS  
**BT**  
 HA  
 EL  
 IDX

# BODY END

## Body Rear End and Opener (Cont'd)

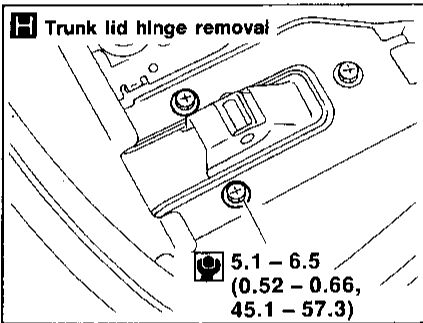
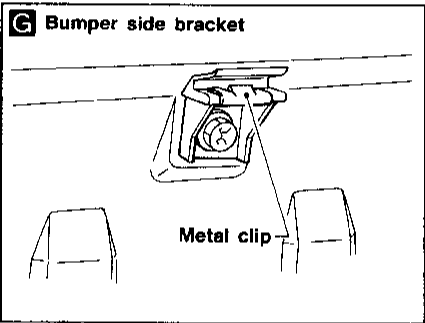
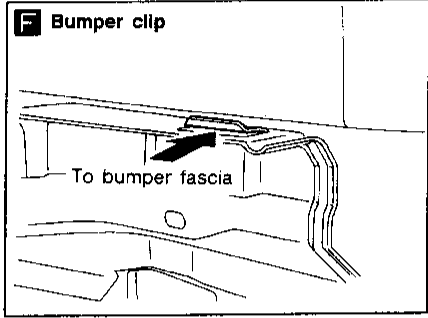
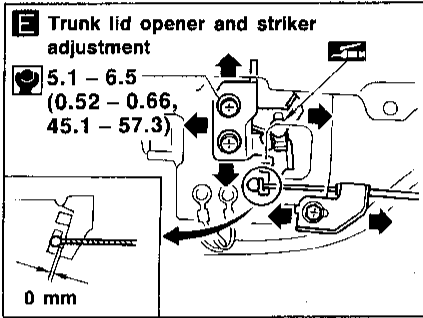
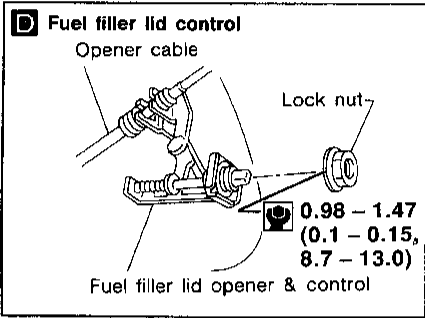
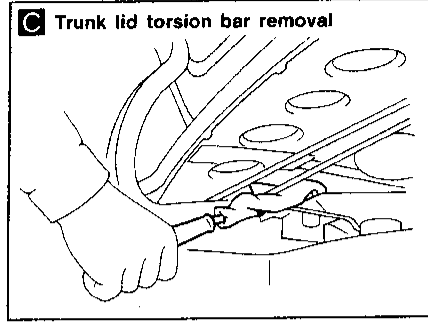
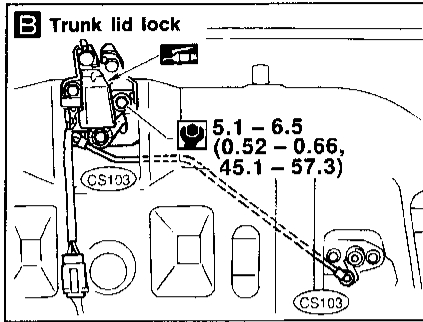
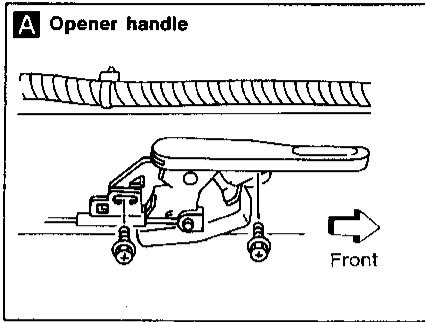

: N·m (kg-m, in-lb)

ABT092

# DOOR

## Front Door

SEC. 800-803-805

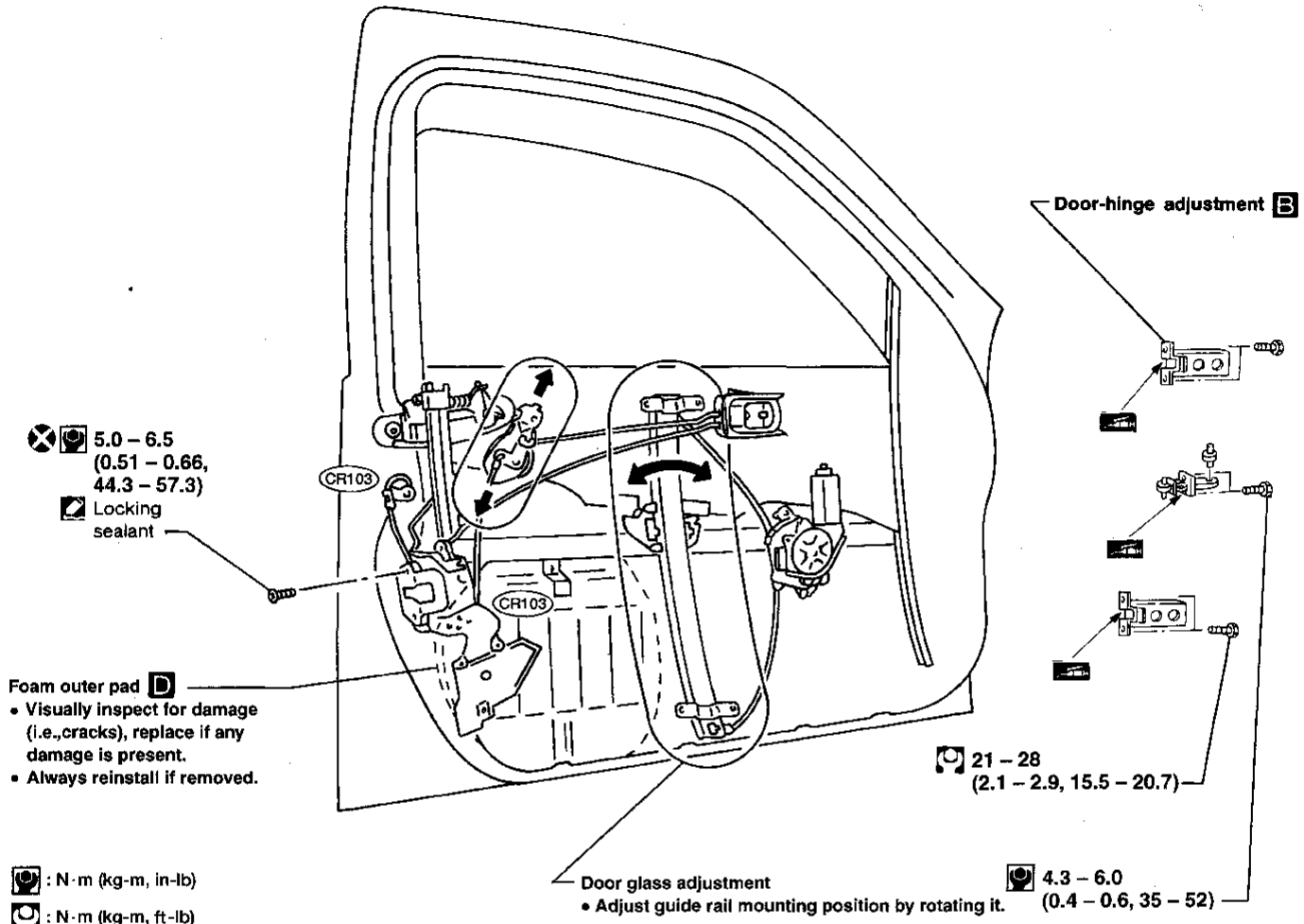

: N·m (kg-m, in-lb)  
 : N·m (kg-m, ft-lb)

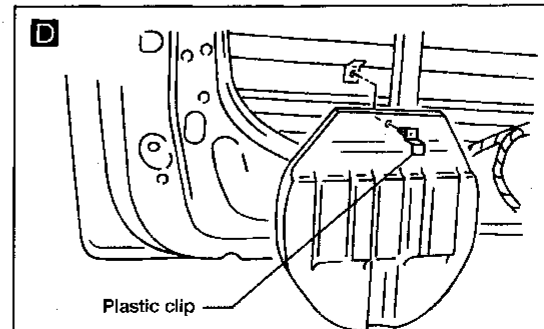
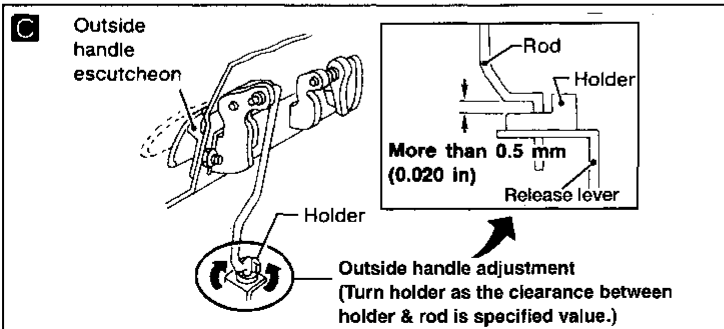
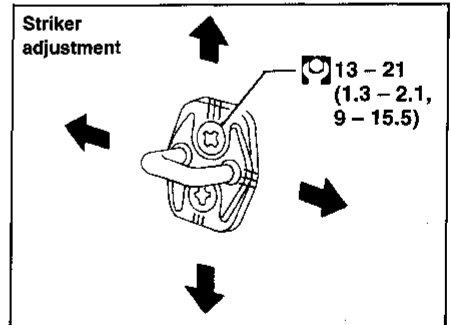
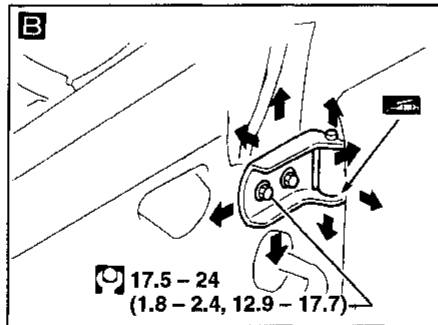
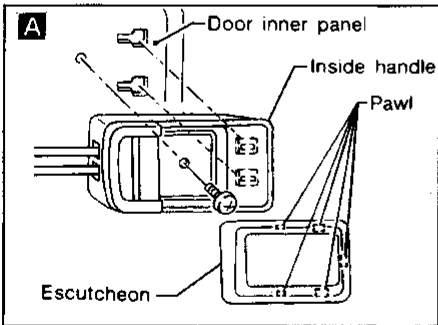

GI  
MA  
EM  
LC  
EC  
FE  
CL  
MT  
AT  
FA  
RA  
BR  
ST  
RS  
BT  
HA  
EL  
IDX

# DOOR

## Rear Door

SEC. 820 • 823 • 825

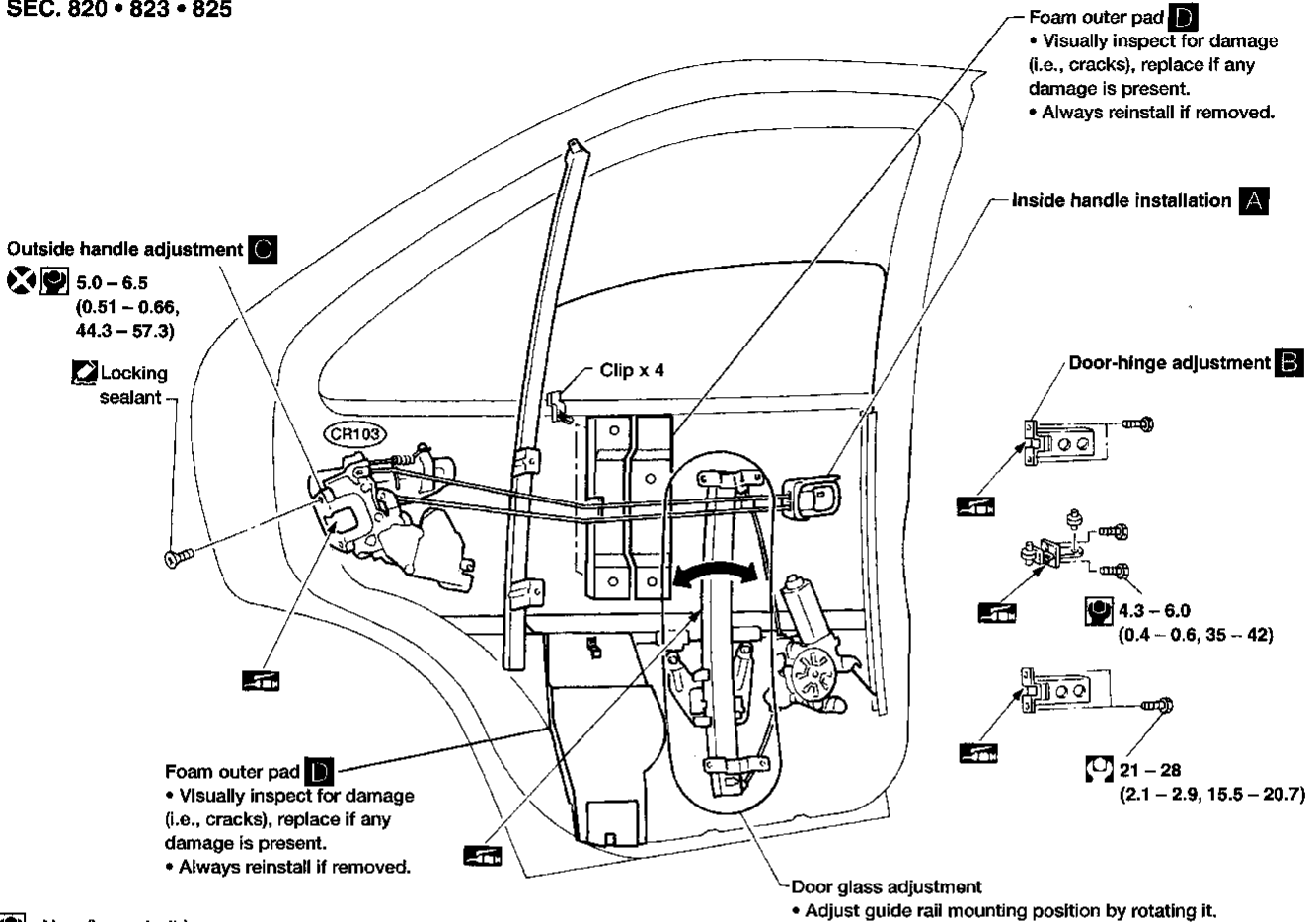

: N·m (kg-m, in-lb)

: N·m (kg-m, ft-lb)

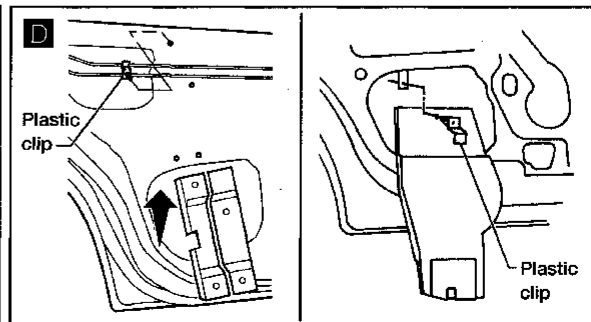
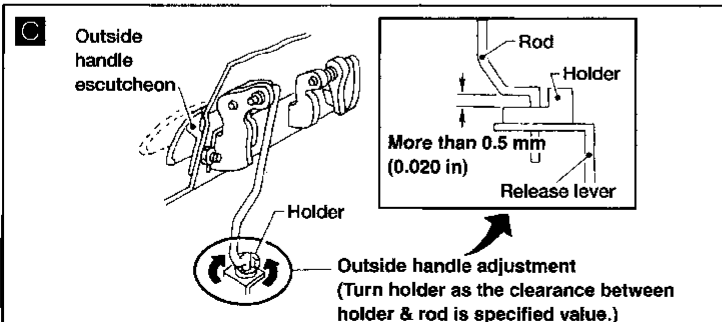
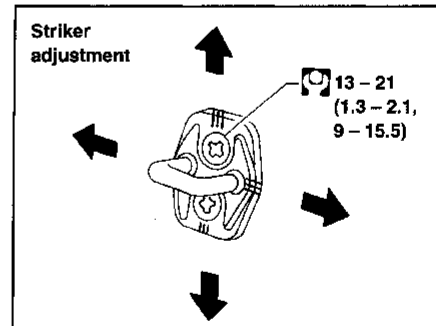
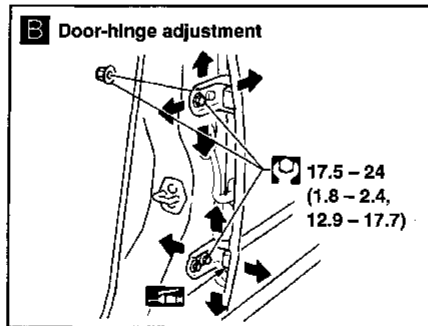
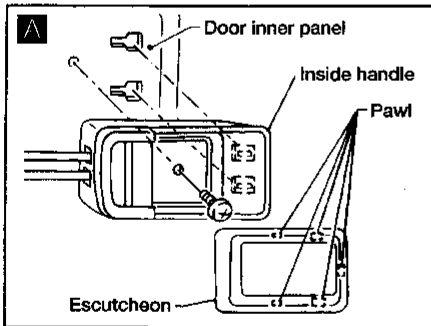

# INSTRUMENT PANEL

## CAUTION:

- Disconnect both terminals from battery in advance.
- Disconnect air bag module connectors in advance.
- Be careful not to scratch pad and other parts.

## REMOVAL — Instrument panel assembly

Instrument panel assembly	Combination meter	Audio & A/C control assembly	Console box
Remove driver air bag module and steering wheel. Refer to RS section and ST section.			
① Instrument lower panel on driver side ● Remove two screws.		<b>A</b>	
② Dash lower reinforcement panel ● Remove two screws.			
③ Steering column cover & combination switch ● Remove six screws.			
④ Cluster lid A ● Remove two screws.		<b>B</b>	
⑤ Combination meter ● Remove three screws, then disconnect harness connectors.			
⑥ Ashtray ● Remove ashtray.			
⑦ Cluster lid C ● Remove mask and screw securing cluster lid C.		<b>C</b>	<b>D</b>
⑧ Audio & A/C control assembly ● Remove eight screws from the instrument panel.			
⑨ Glove box assembly ● Remove two clips.		<b>E</b>	⑧ -1 A/C control assembly ⑧ -2 Audio ⑧ -3 Cup holder
⑩ Front passenger air bag module. ● Refer to RS section.			
⑪ A/T finisher or M/T shifter finisher.			<b>F</b>
⑫ Rear console ● Remove mask and four screws.			<b>G</b>
⑬ Front console ● Remove four screws.			<b>H</b>
⑭ Front pillar garnish ● Refer to BT-17.			<b>BT</b>
⑮ Dash side lower garnish ● Refer to BT-17.			<b>HA</b>
⑯ Instrument panel mask ● Remove instrument panel mask.		<b>U</b>	<b>EL</b>
⑰ Instrument panel assembly ● Remove nuts & bolts marked ★.			<b>IDX</b>

GI

MA

EM

LC

EC

FE

CL

MT

AT

FA

RA

BR

ST

RS

**BT**

HA

EL

IDX

# INSTRUMENT PANEL

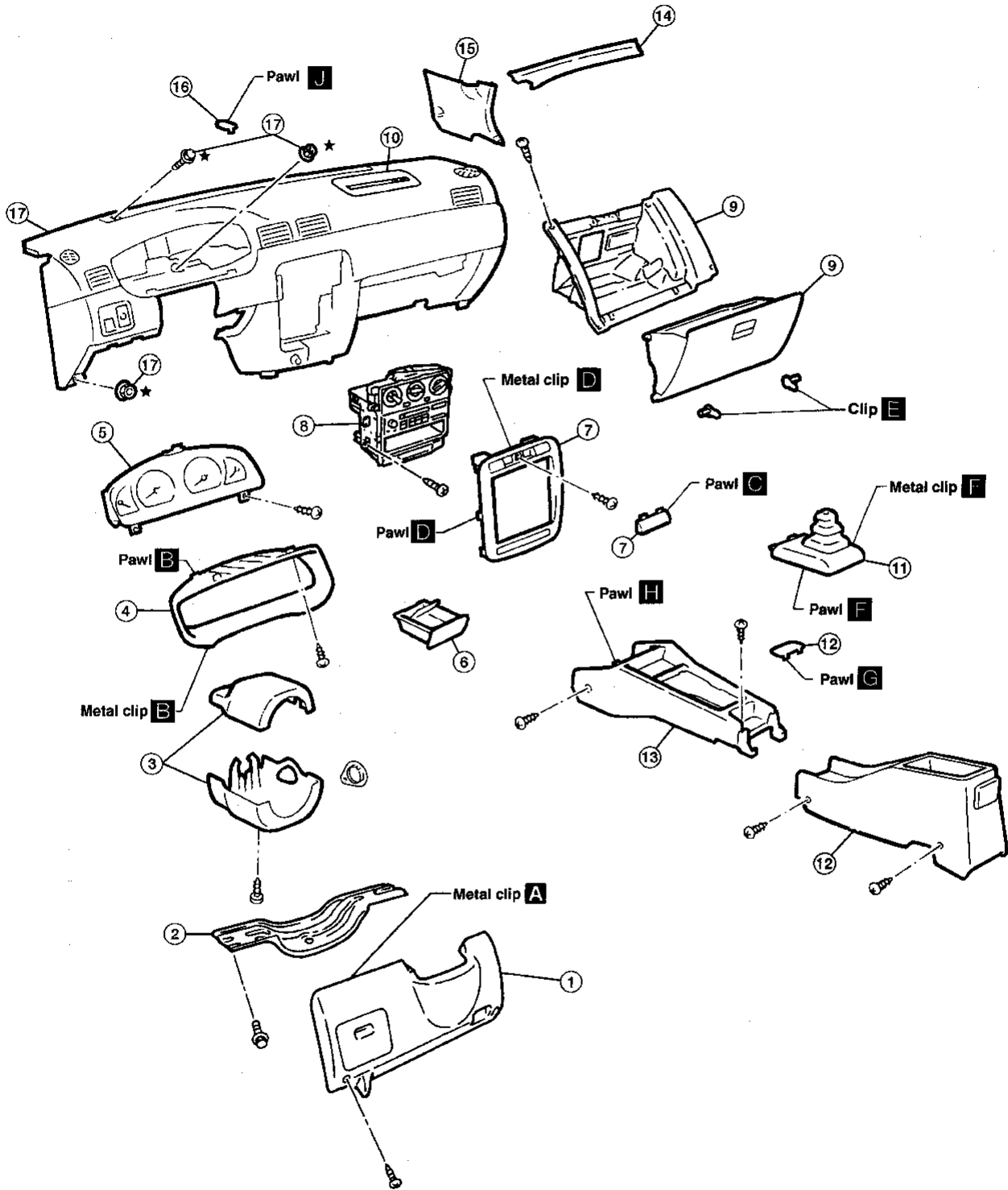

★ : Instrument panel assembly mounting bolts and nuts.

# INSTRUMENT PANEL

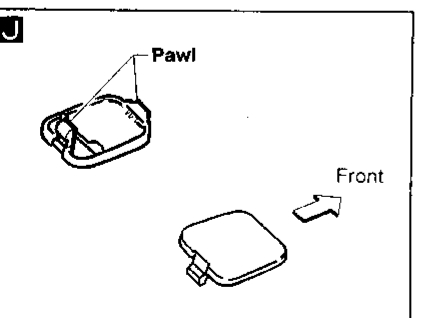
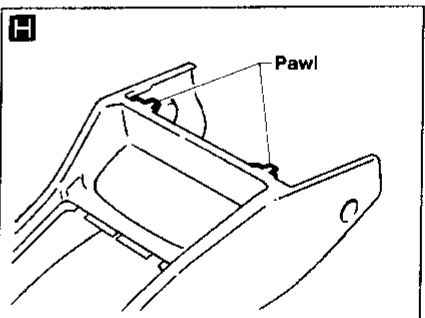
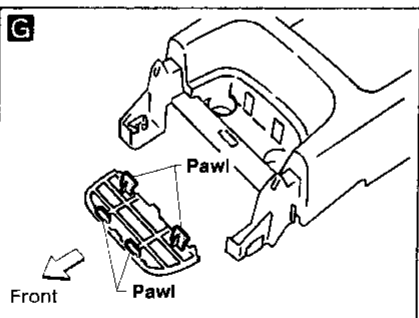
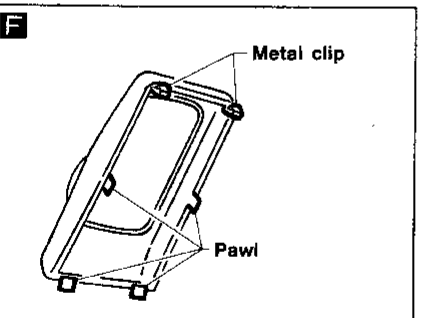
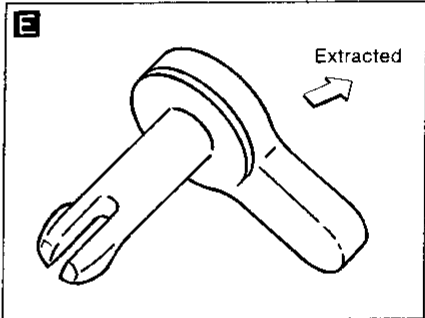
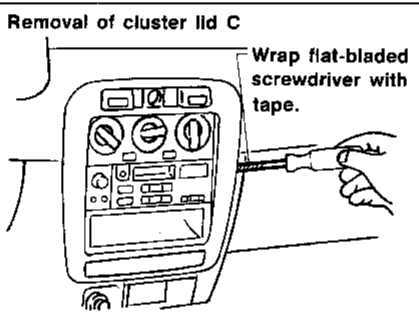
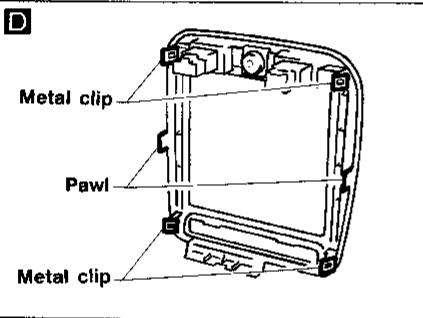
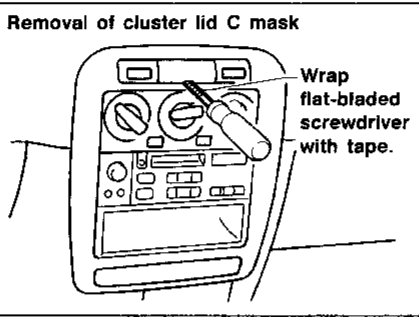
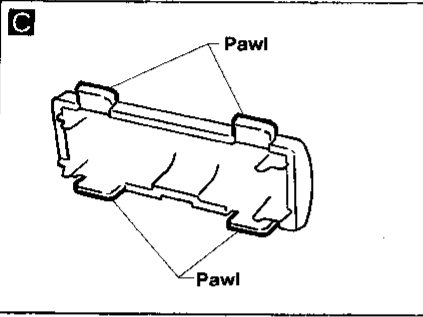
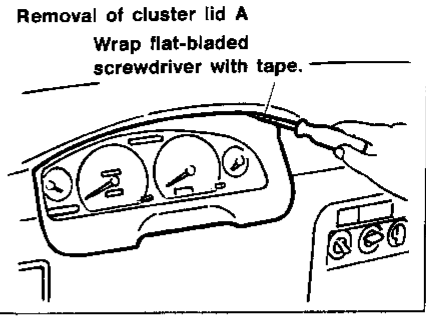
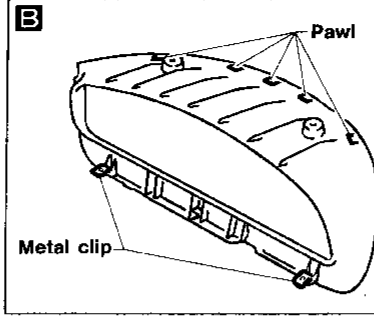
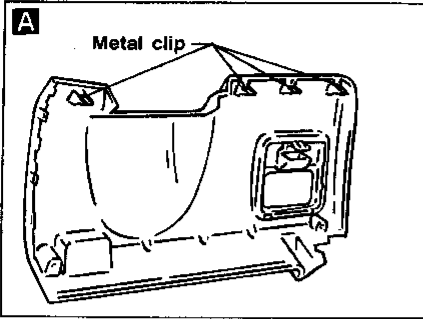

GI  
MA  
EM  
LC  
EC  
FE  
CL  
MT  
AT  
FA  
RA  
BR  
ST  
RS  
BT  
HA  
EL  
IDX

# INTERIOR TRIM

## Side and Floor Trim

### CAUTION:

Wrap the tip of flat-bladed screwdriver with a cloth when removing metal clips from garnishes.

### REMOVAL — Body side trim

Remove A/T finisher or M/T shift lever boot.

Remove front console and rear console. Refer to BT-13.

Remove front and rear seats.

- ① Remove kick plates.
- ② Remove dash side lower garnish. **A**
- ③ Remove body side welts.
- ④ Remove front pillar garnish. **B**  
Remove front seat belt floor anchor bolt.  
Remove rear seat belt floor anchor bolt.
- ⑤ Remove center pillar lower garnish.  
Remove adjuster cover and pillar anchor bolt. Refer to RS-5.
- ⑥ Remove center pillar upper garnish. **C**
- ⑦ Remove rear pillar garnish. **E**
- ⑧ Remove parcel shelf.
- ⑨ Remove welt.
- ⑩ Remove rear seat back finishers. **F**
- ⑪ Remove floor carpet.

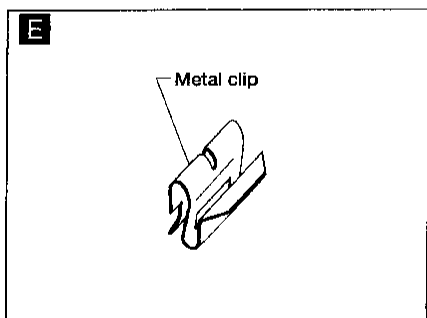
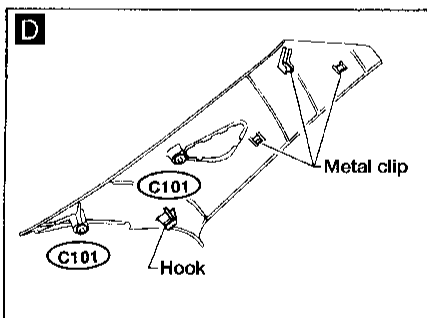
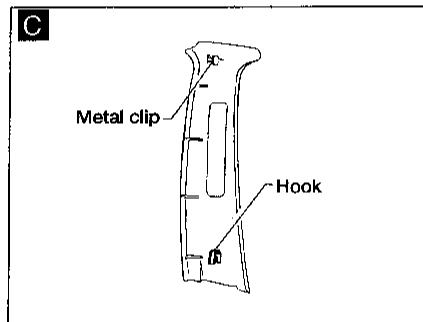
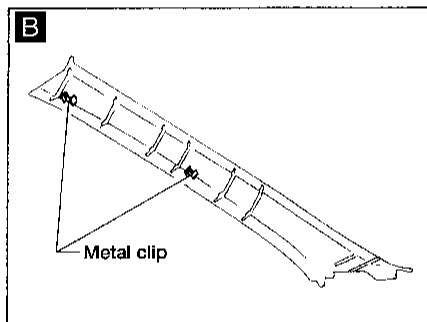
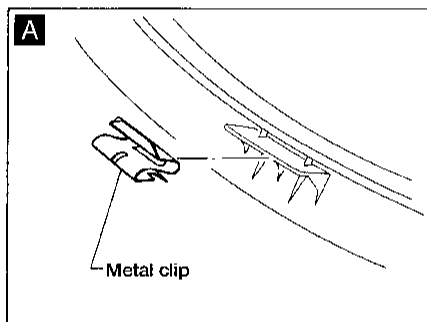

ABT409



# INTERIOR TRIM

## Side and Floor Trim (Cont'd)

SEC. 749-769-799

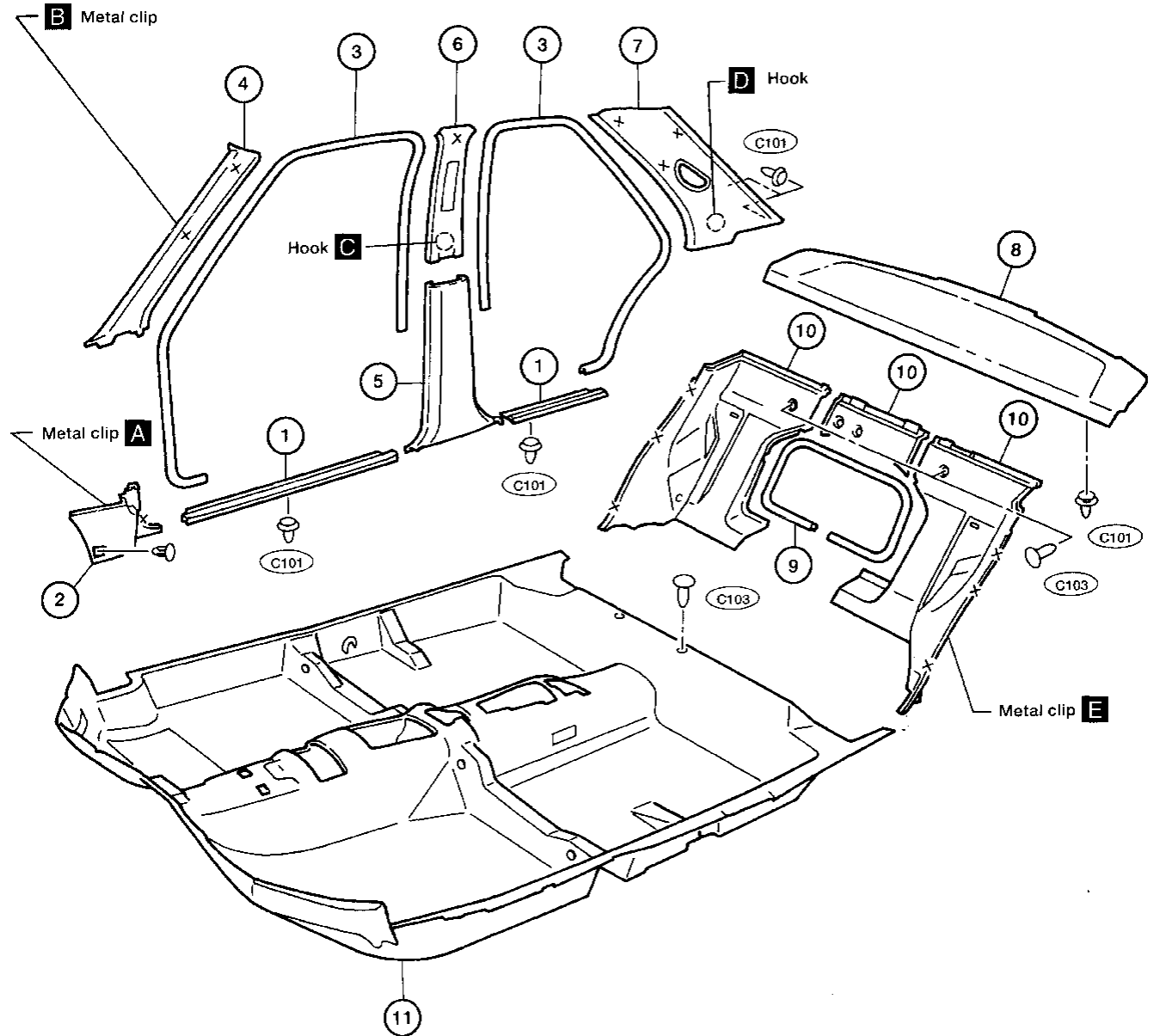

X: Metal clips

GI  
MA  
EM  
LC  
EC  
FE  
CL  
MT  
AT  
FA  
RA  
BR  
ST  
RS  
**BT**  
HA  
EL  
IDX

# INTERIOR TRIM

## Door Trim

### CAUTION:

Wrap the tip of a flat-bladed screwdriver with a cloth when prying pawls from door trim.

### REMOVAL

- ① Remove power window switch(es), then disconnect the connector(s) (models equipped with power window). **A**
- Do not lift the front of the power window switch assembly.  
Remove window regulator handle (models without power window). **B**
- ② Remove screws and clips **C103**.
- ③ Reach behind and carefully pull door trim panel from inside handle until finisher pops off.
- ④ Lift out door trim.

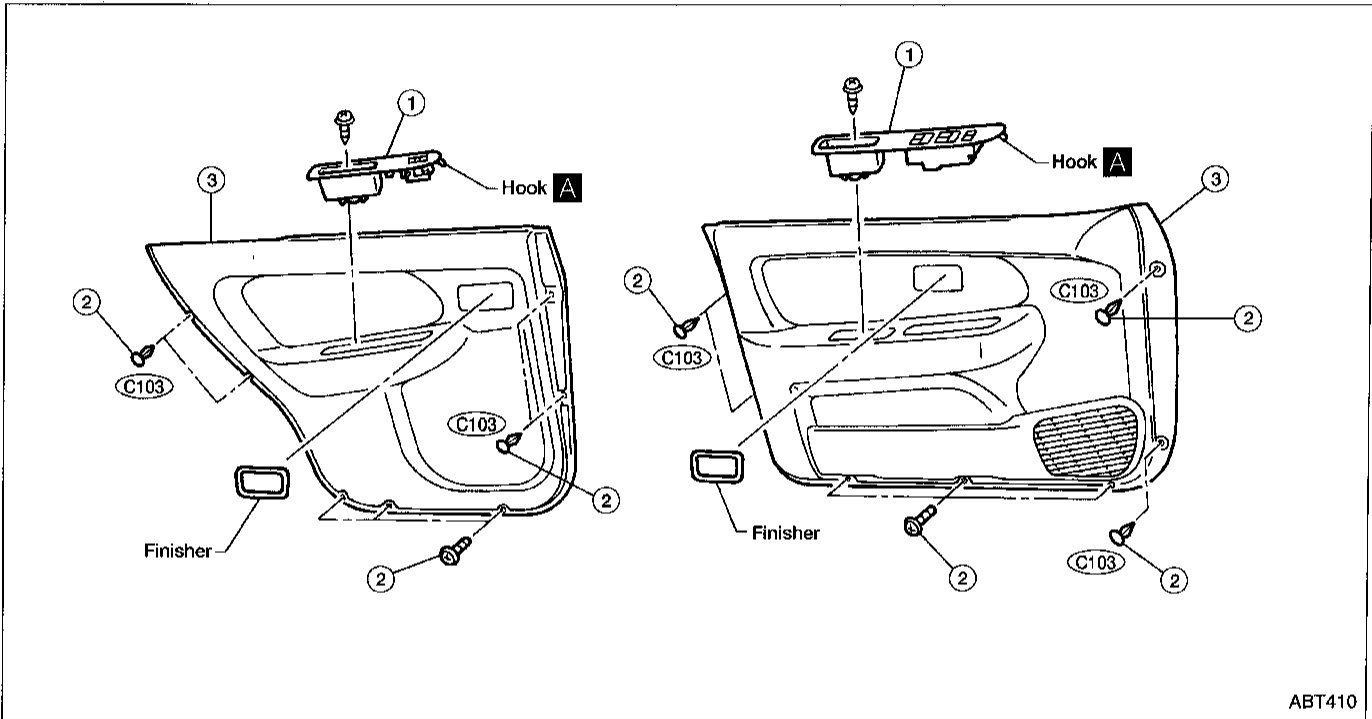

ABT410

# INTERIOR TRIM

## Door Trim (Cont'd)

GI  
MA  
EM  
LC  
EC  
FE  
CL  
MT  
AT  
FA  
RA  
BR  
ST  
RS  
BT  
HA  
EL  
IDX

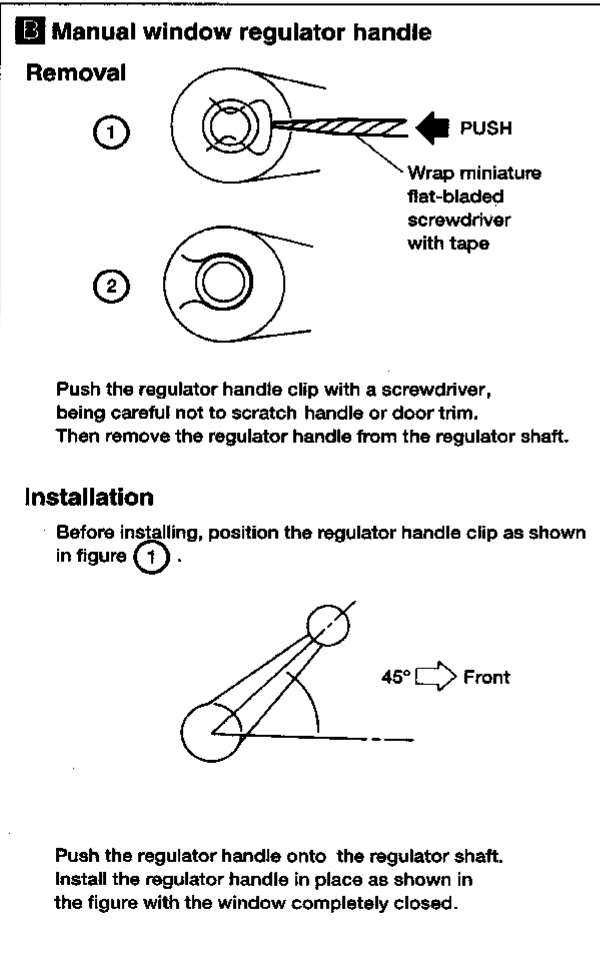
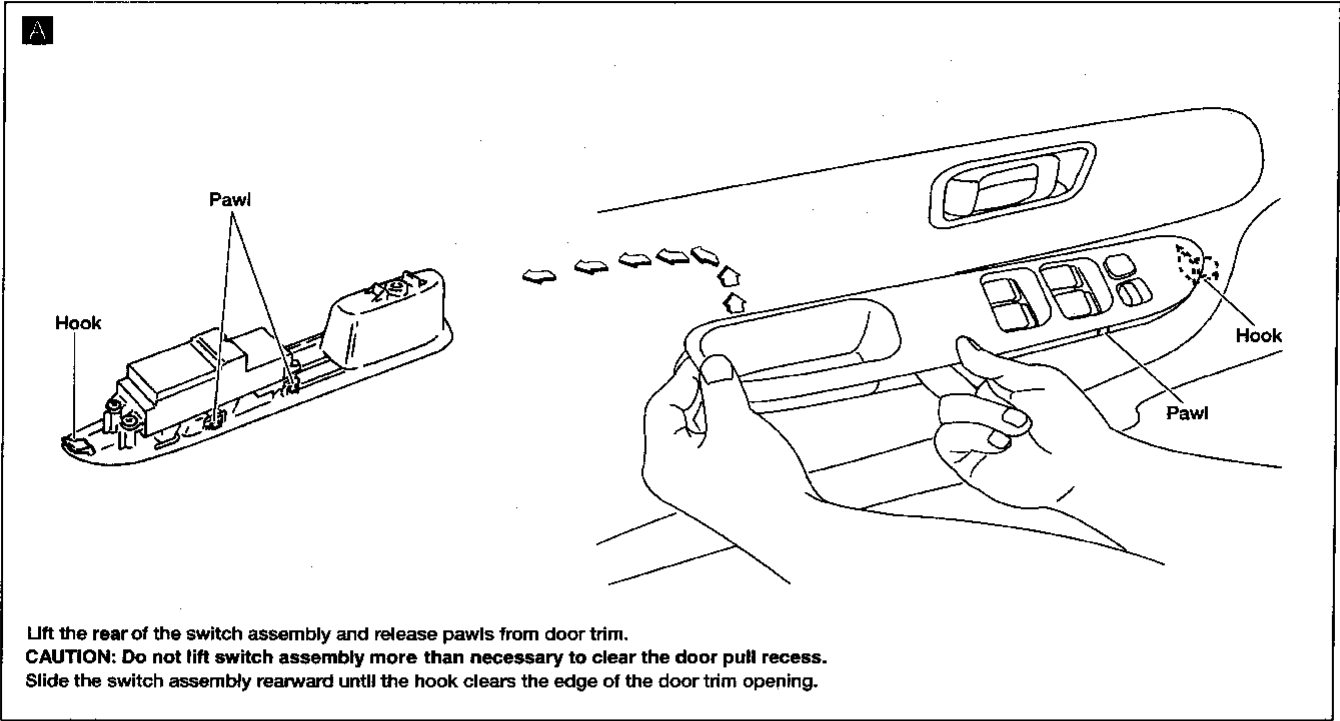

# INTERIOR TRIM

## Roof Trim

### CAUTION:

- Disconnect both terminals from battery in advance.

### REMOVAL

Remove driver air bag module and steering wheel. Refer to RS and ST section.

Fully tilt front right and left seatbacks backward.

Remove front pillar garnish. Refer to BT-16.

Remove center pillar upper garnish and rear pillar garnish. Refer to BT-16.

- ① Remove sun visors.
- ② Remove interior lamp.
- ③ Remove assist grips (if equipped) or coat hooks.
- ④ Remove sunroof welt.
- ⑤ Remove sunroof switch.
- ⑥ Remove clips attached to roof.
- ⑦ Take out headlining from the front passenger door.

SEC. 738-963-964

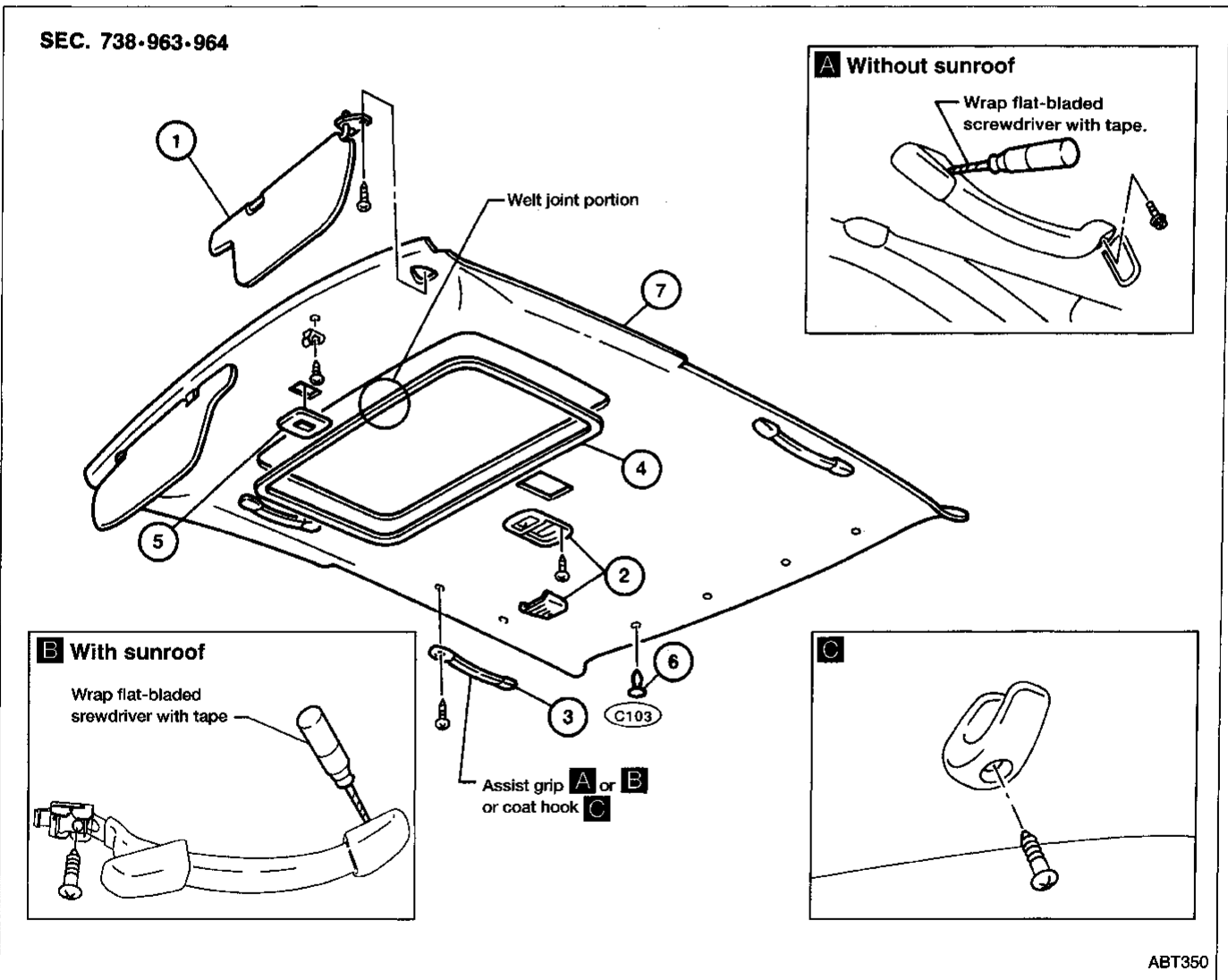

ABT350

# INTERIOR TRIM

## Trunk Room Trim

SEC. 849

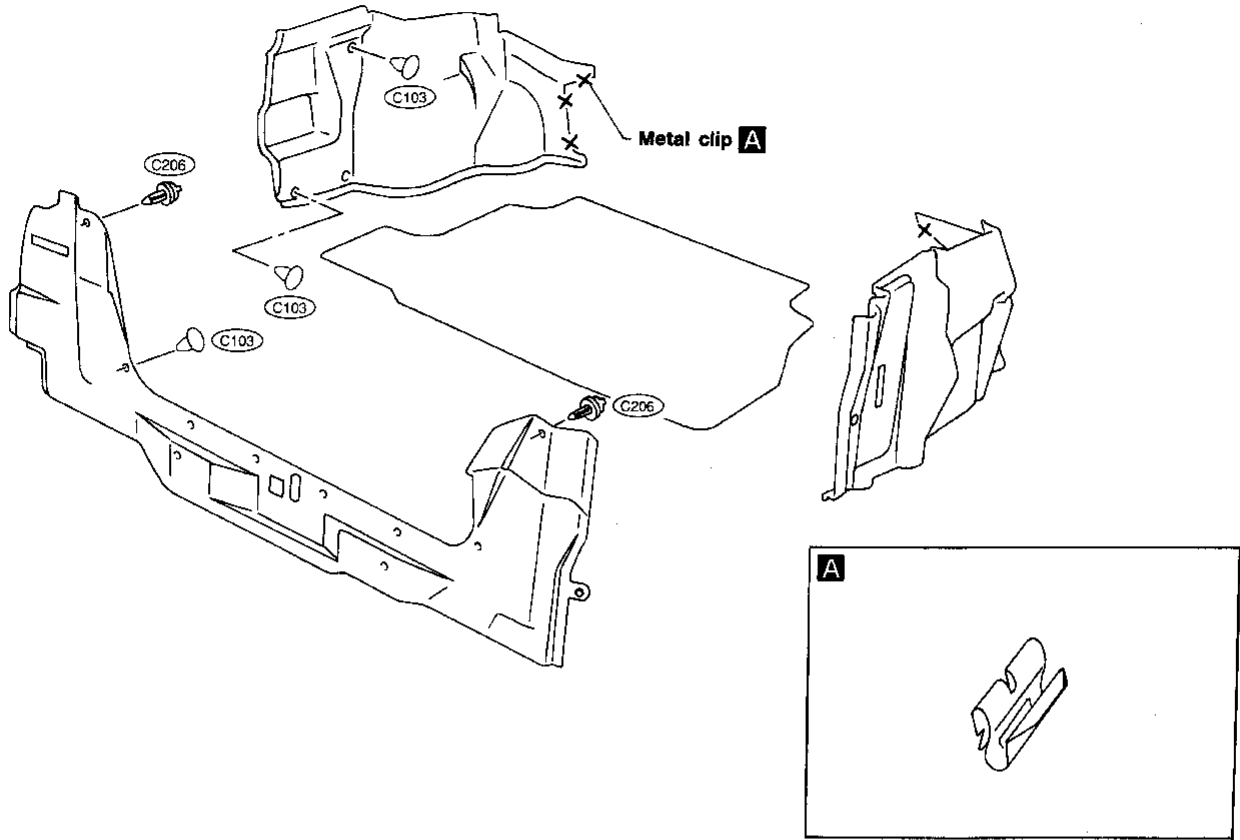

MBT009A

GI  
MA  
EM  
LC  
EC  
FE  
CL  
MT  
AT  
FA  
RA  
BR  
ST  
RS  
BT  
HA  
EL  
IDX

# EXTERIOR

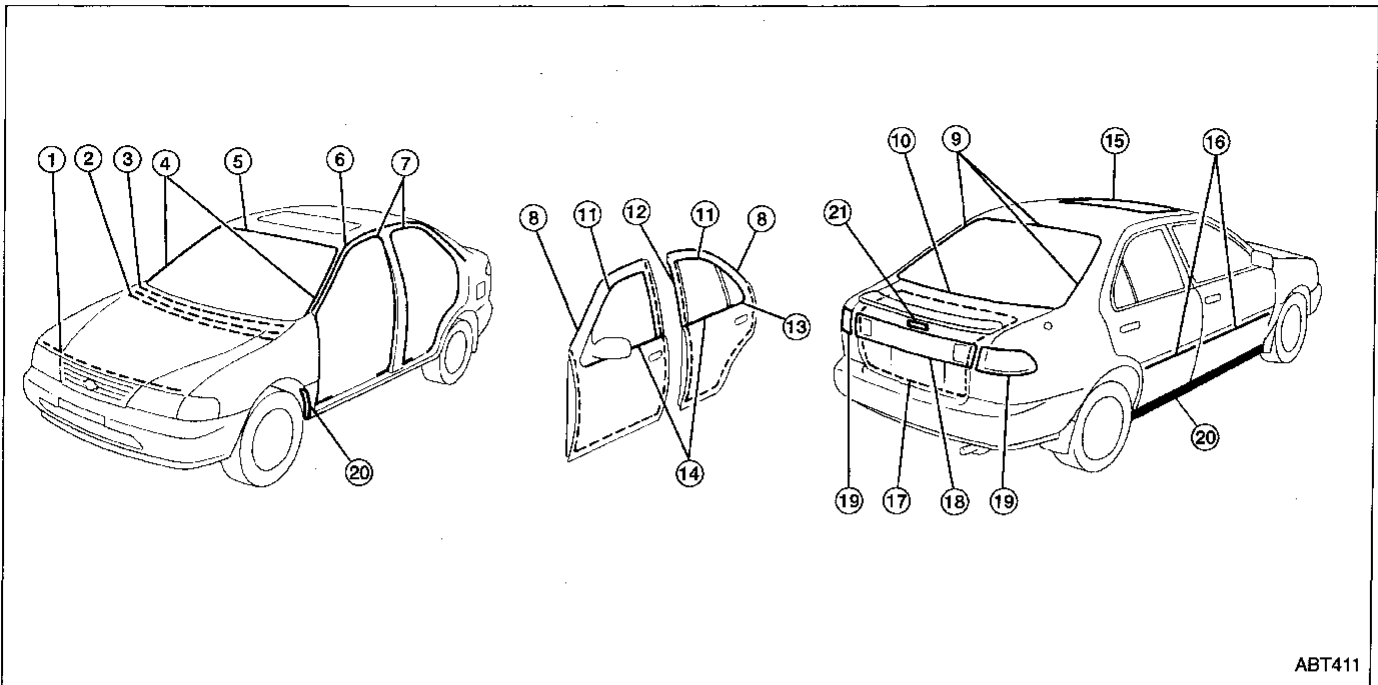

ABT411

## ① Hood front seal

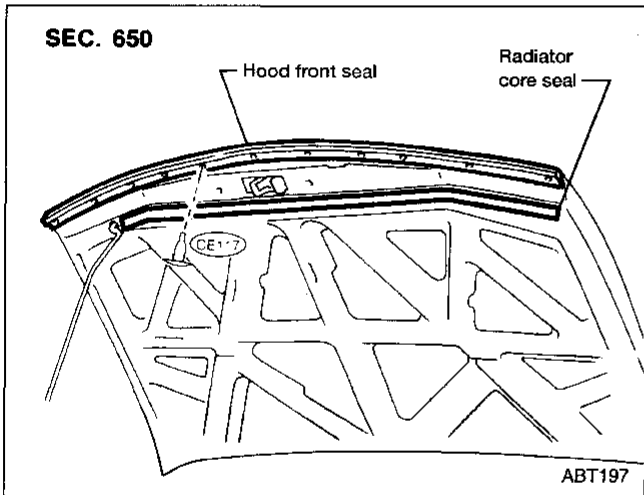

## ② ③ Cowl top seal and cowl top grille

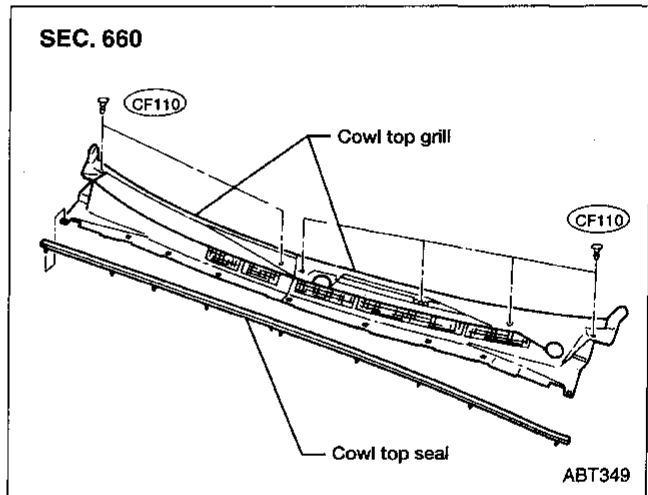

## ④ Windshield side molding

Mounted with screws.

⑤ Windshield upper molding

SEC. 720

1. Cut off urethane adhesive at glass end.
2. Remove old urethane adhesive from panel surface.
3. Set molding fastener and apply primer to body panel, and apply urethane adhesive to body.

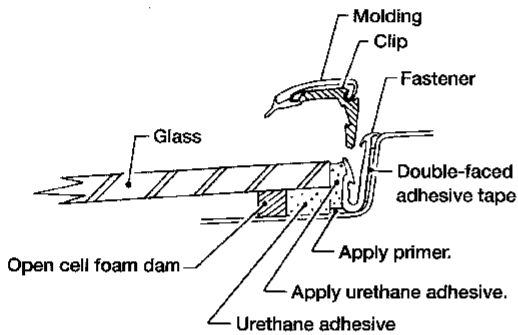
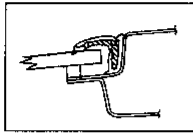

4. Install molding by aligning the molding mark located on center with vehicle center. Be sure to install tightly so that there is no gap around the corner.

ABT286

⑥ Drip weatherstrip

SEC. 720-767

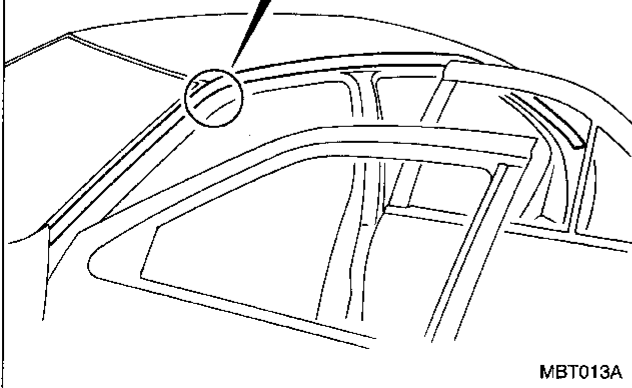
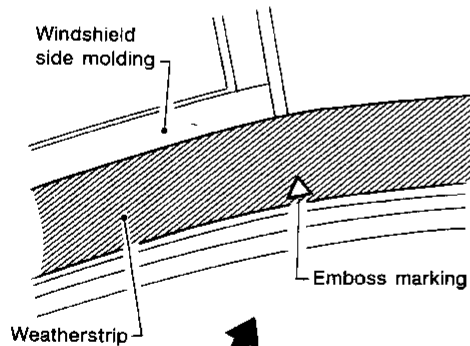

MBT013A

⑦ Body side welt

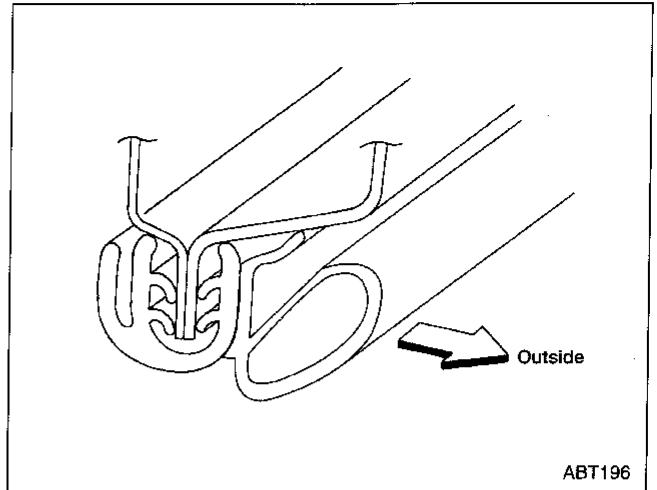

ABT196

⑧ Door weatherstrip

SEC. 800-820

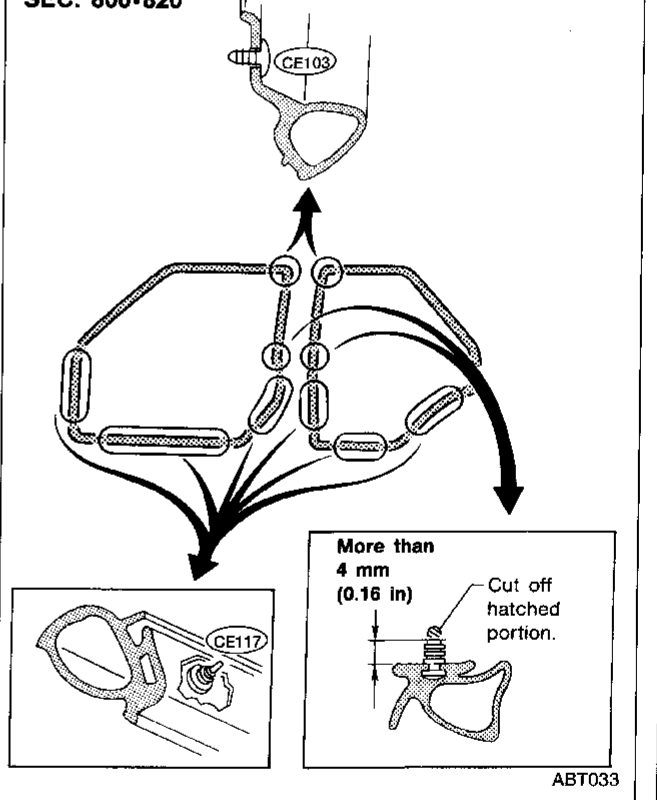

ABT033

⑨ Rear window upper molding and side molding

Basically the same as windshield upper molding. Refer to ⑤ Windshield upper molding.

⑩ Rear window lower molding

Mounted with screws.

GI

MA

EM

LC

EC

FE

CL

MT

AT

FA

RA

BR

ST

RS

BT

HA

EL

IDX

11 Door sash molding

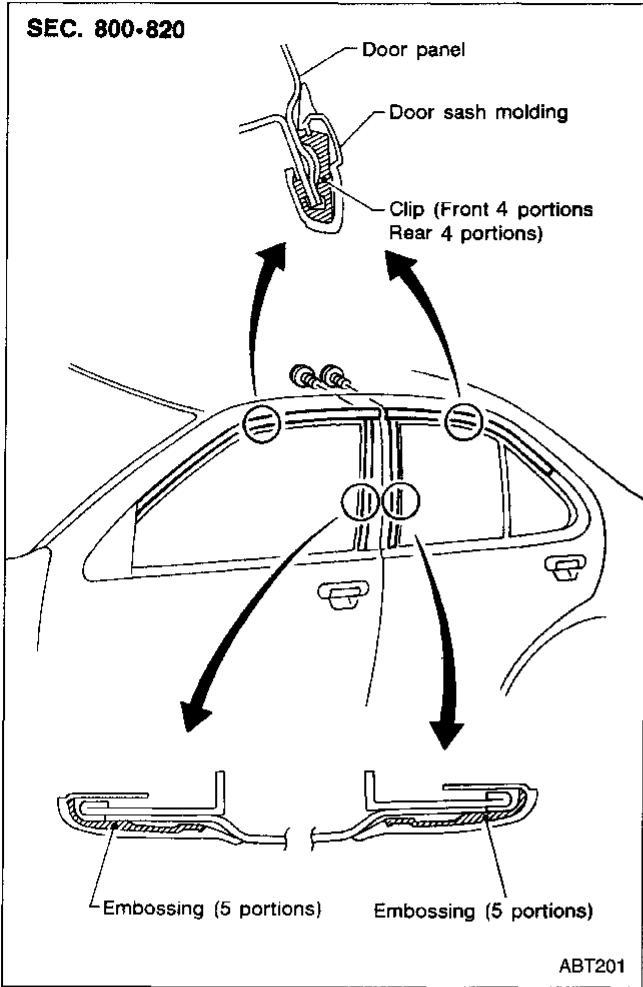

13 Rear door corner molding

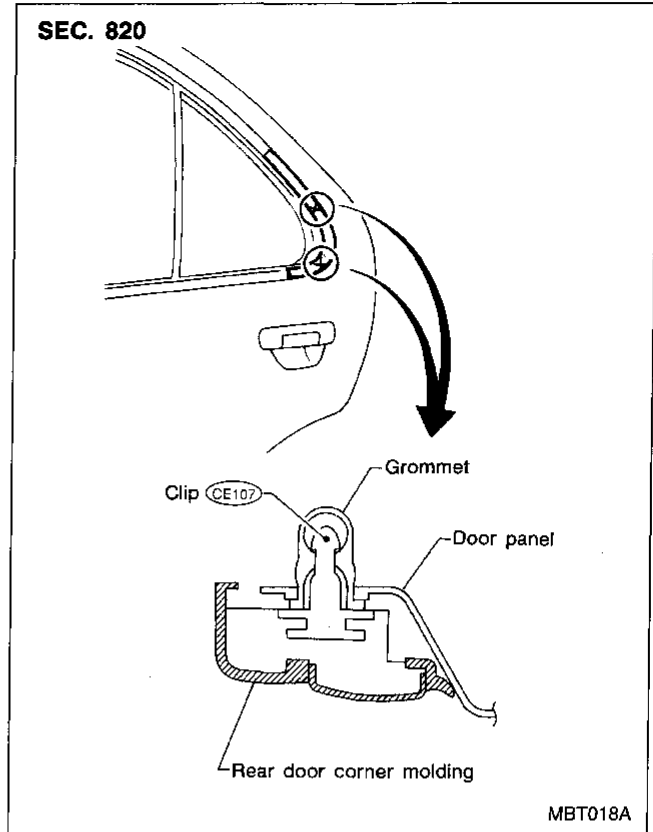

12 Rear door parting seal

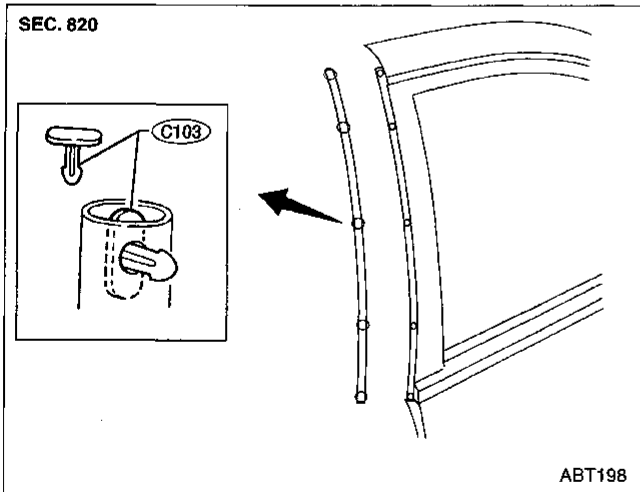

14 Door outside molding

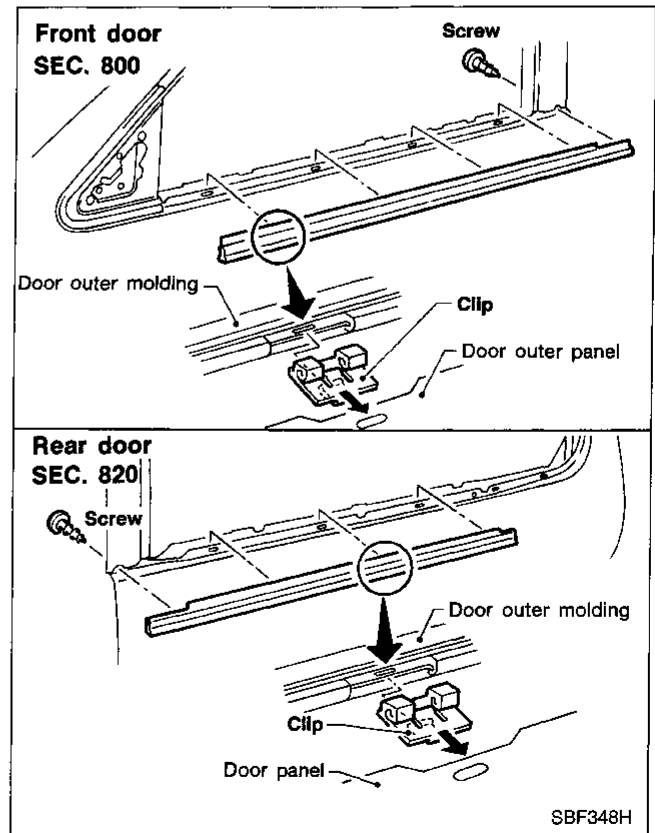



## 15 Sunroof lid weatherstrip

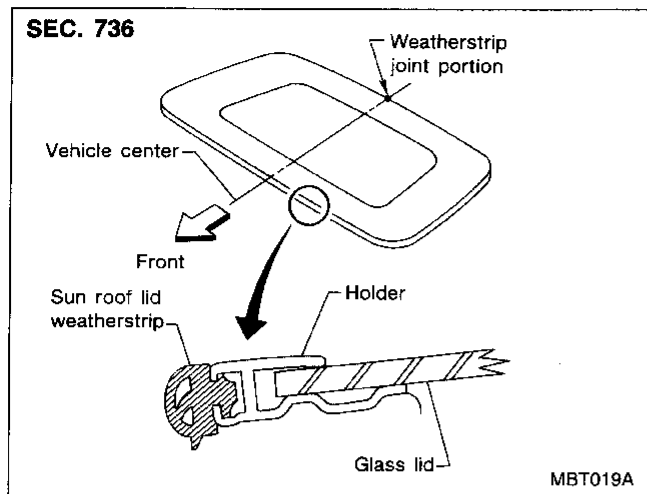

## 17 Trunk lid weatherstrip

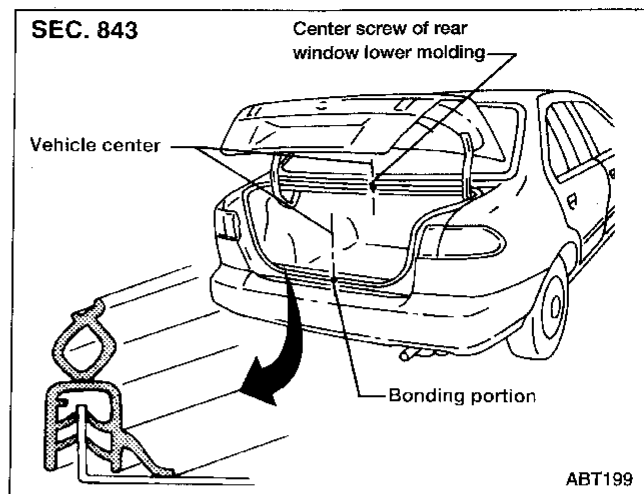

## 16 Side guard molding

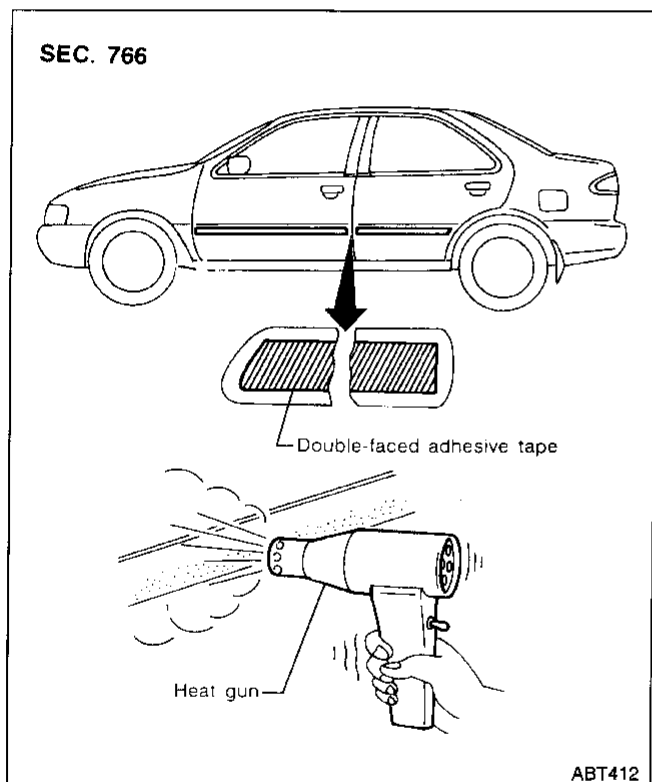

## 18 Trunk lid finisher

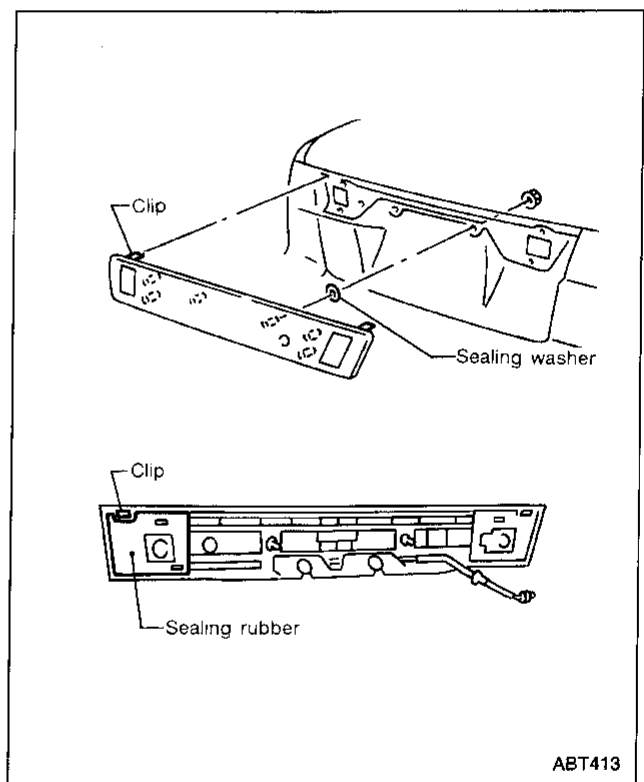

- With a vehicle coated with Hard Clear Coat, use double-faced 3M adhesive tape Product No. 4210 or equivalent, after priming with 3M primer Product No. N-200 or C-100 or equivalent.

GI

MA

EM

LC

EC

FE

CL

MT

AT

FA

RA

BR

ST

RS

BT

HA

EL

IDX

## EXTERIOR

### ①9 Rear combination lamp

Rear combination lamps are installed with nuts and butyl sealant.

SEC. 265

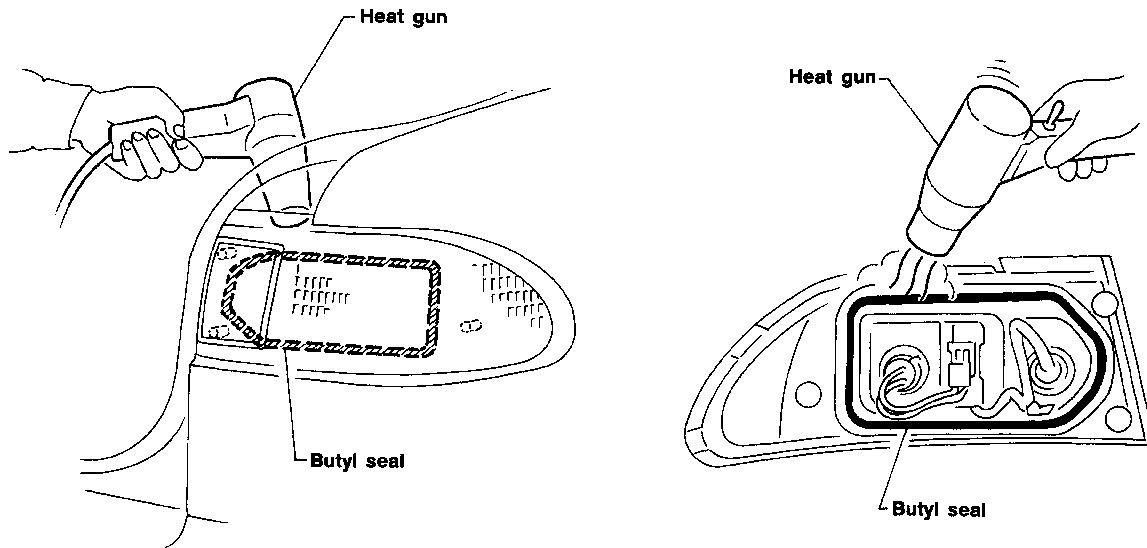

- Apply butyl seal evenly as it tends to become thin in the corners.
- Warm up lamp assembly area to a temperature of a little below 60°C (140°F).

MBT021A

# EXTERIOR

## 20 Fender and center mudguard

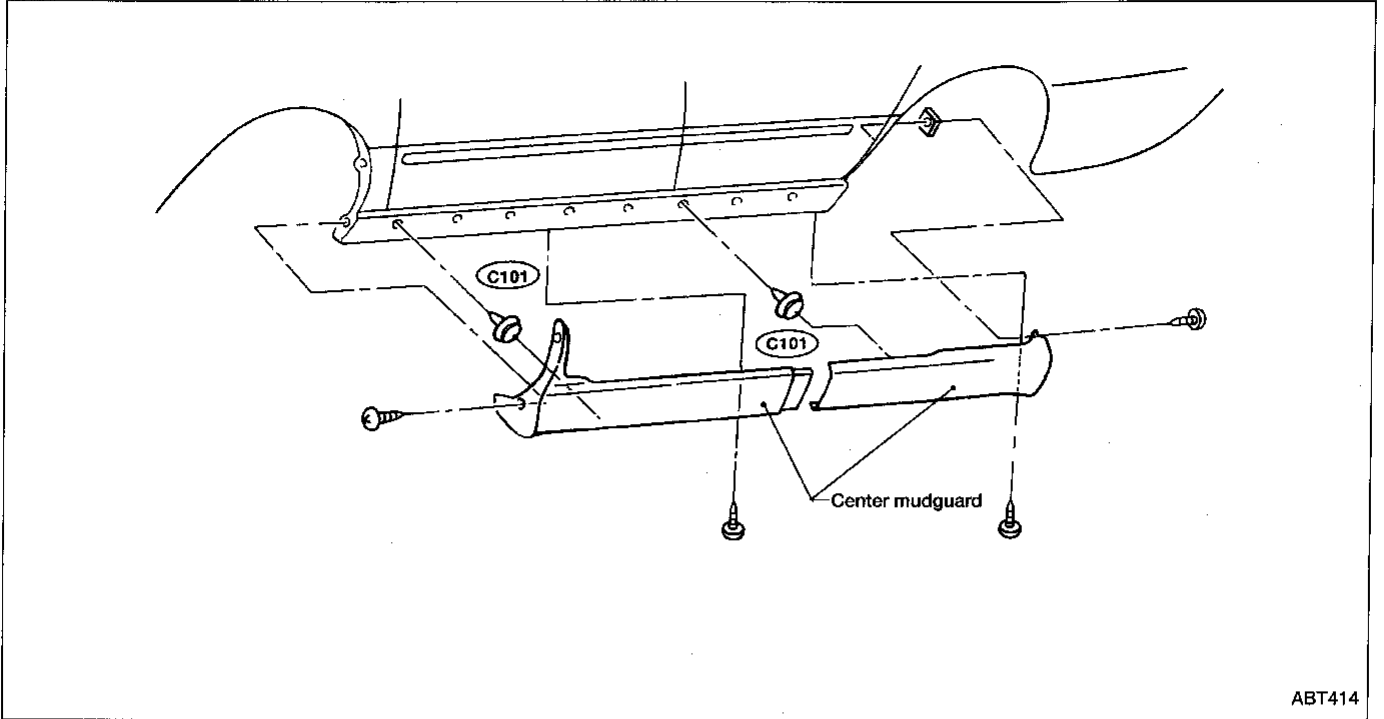

## 21 Rear air spoiler and high-mounted stop lamp

- When installing, make sure that there are no gaps or waves at ends of air spoiler.
- Before installing spoiler, clean and remove oil from surface where spoiler will be mounted.

SEC. 960

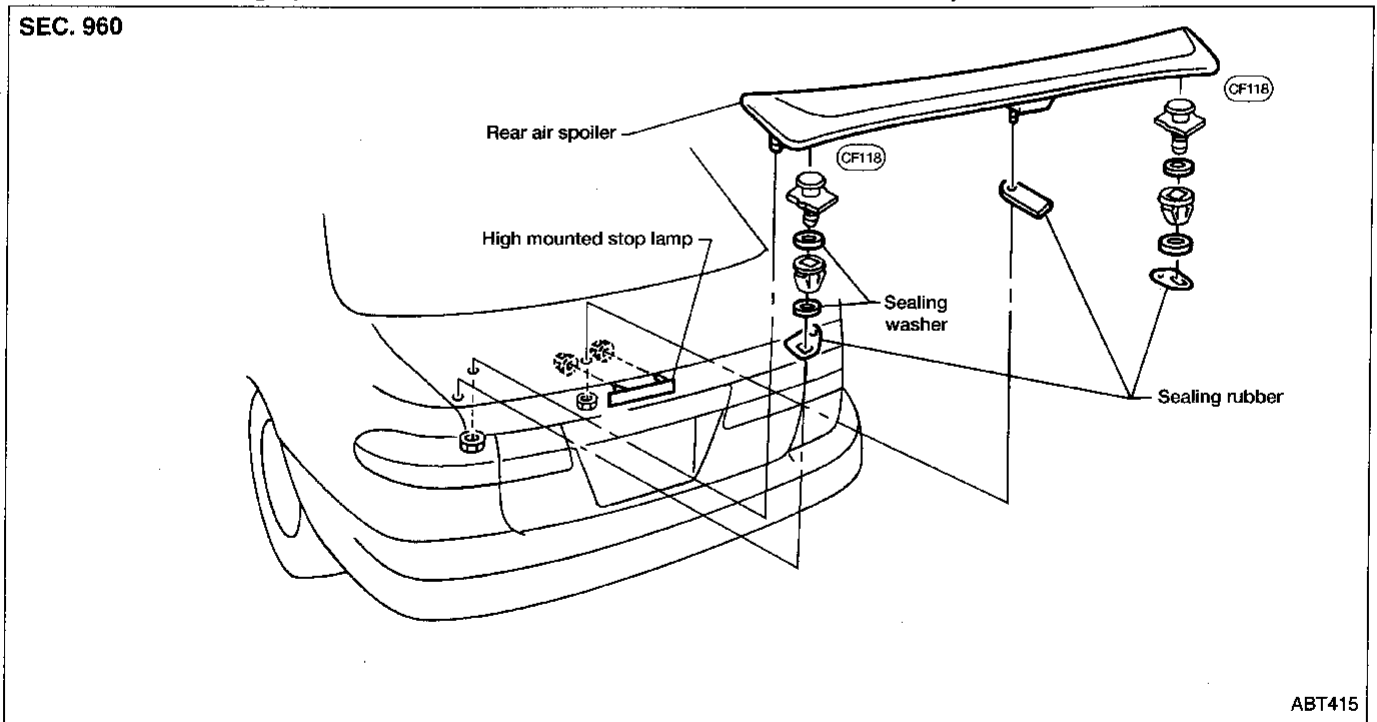

GI

MA

EM

LC

EC

FE

CL

MT

AT

FA

RA

BR

ST

RS

**BT**

HA

EL

IDX

# SEAT

When removing or installing the seat trim, handle it carefully to keep dirt out and avoid damage.

## Front Seat

SEC. 870

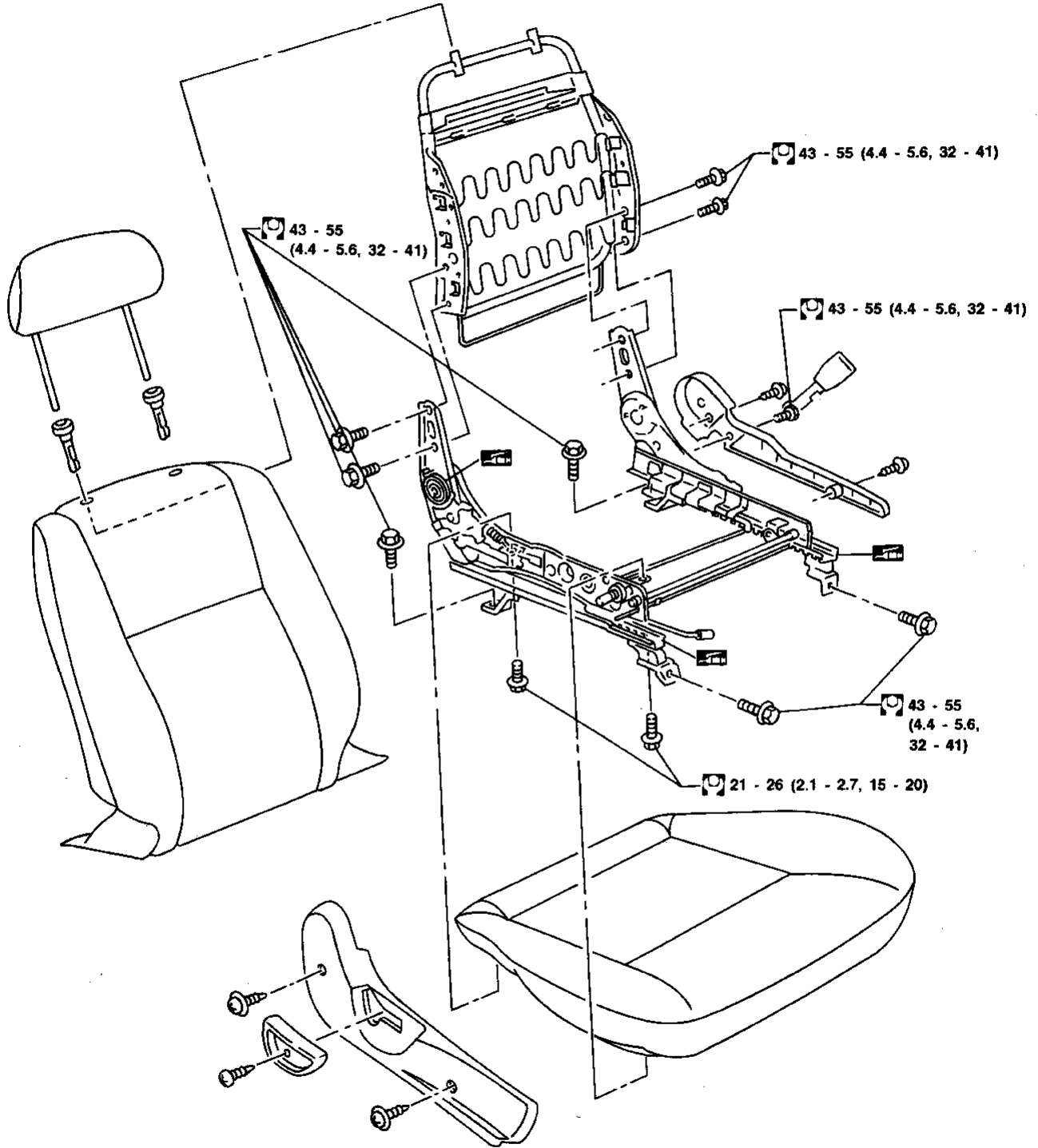

: N·m (kg·m, ft·lb)

# SEAT

## Rear Seat

SEC. 880  
Type 1 (Fixed type)

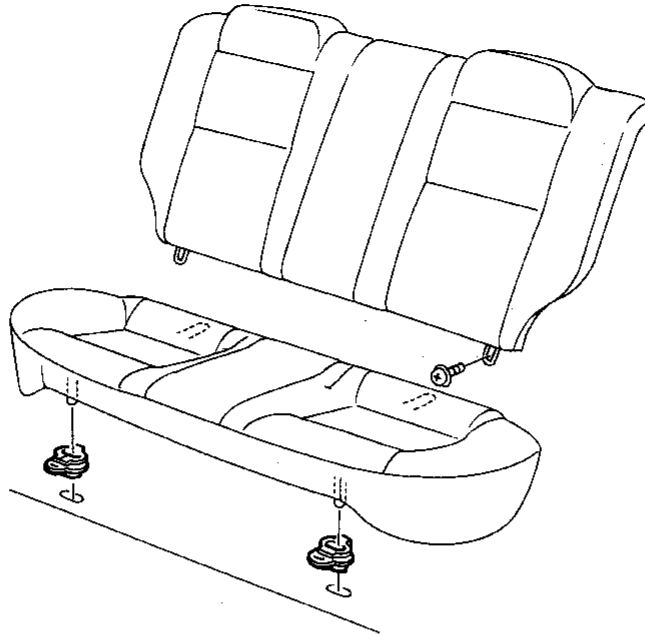

Type 2 (Folding type)

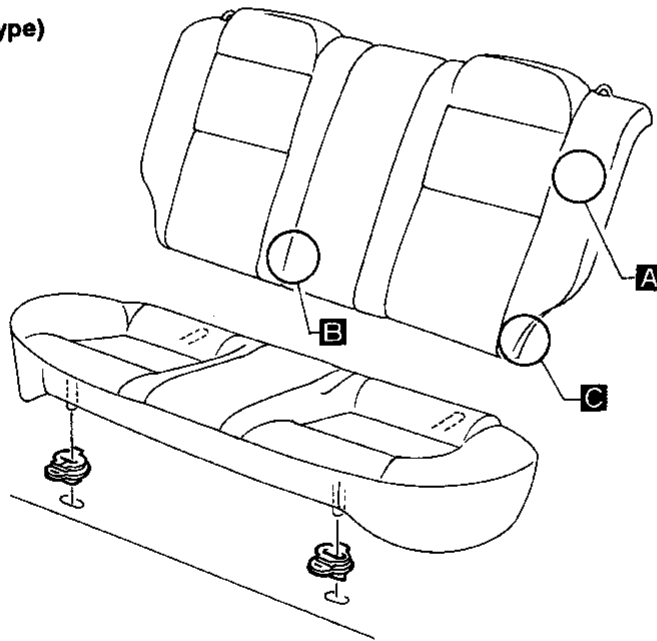

: N·m (kg-m, ft-lb)

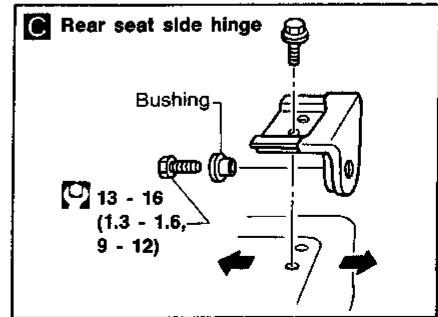
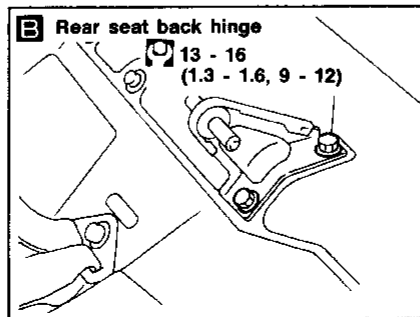
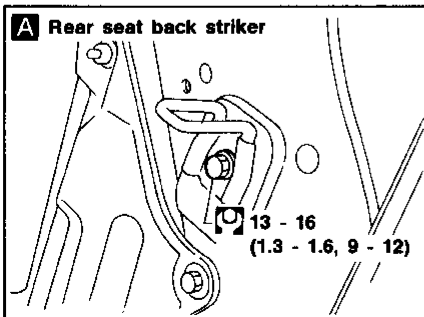

GI

MA

EM

LC

EC

FE

CL

MT

AT

FA

RA

BR

ST

RS

**BT**

HA

EL

IDX

# SUNROOF

SEC. 736

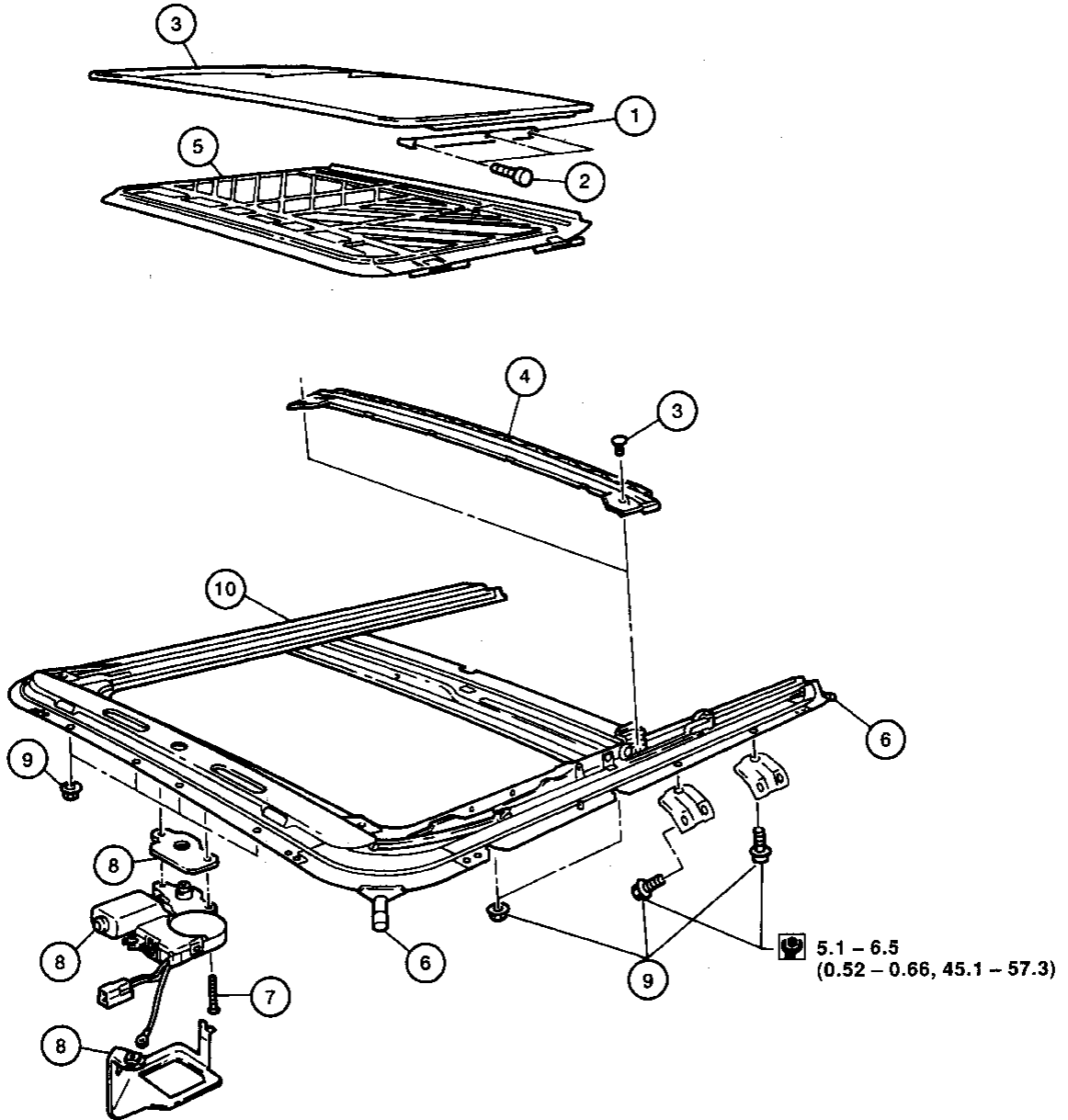

 : N·m (kg·m, in·lb)

# SUNROOF

## Removal

- After any repair, check sunroof operation and lid alignment.
- Handle finisher plate and glass lid with care so not to cause damage.
- To ease installation, mark each point before removal.

### CAUTION:

- Always work with a helper.

### SUNROOF LID ASSEMBLY

Open sunroof shade.

Close sunroof lid.

- ① Remove side trim.
- ② Remove the six bolts securing sunroof lid assembly to sunroof assembly.

### SHADE ASSEMBLY

- ③ After removing sunroof lid assembly, remove two screws securing drain channel.
- ④ Remove drain channel.
- ⑤ Remove shade assembly.

### SUNROOF ASSEMBLY

Remove headlining. Refer to BT-20.

Disconnect interior lamp harness.

- ⑥ Disconnect front and rear drain hoses.  
Remove assist grip brackets.
- ⑦ Remove screws securing sunroof motor to sunroof assembly.
- ⑧ Remove sunroof motor and bracket.
- ⑨ Remove nuts and bolts securing sunroof assembly to roof.
- ⑩ Remove sunroof assembly.

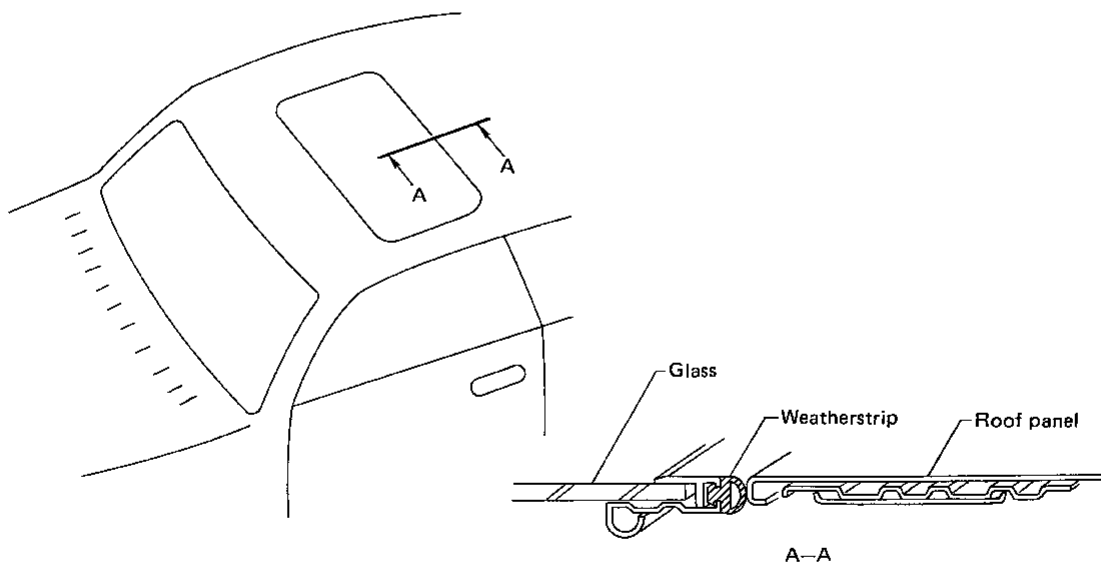

GI

MA

EM

LC

EC

FE

CL

MT

AT

FA

RA

BR

ST

RS

**BT**

HA

SBF918F

EL

IDX

# SUNROOF

## Trouble Diagnoses

### DIAGNOSTIC TABLE

NOTE: For "Wiring Diagram", refer to "ELECTRIC SUNROOF" in EL section.

		Check items (Components)				
		Wind deflector	Drain hoses	Weatherstrip	Link and wire assembly	Adjustment
Reference page		BT-32	BT-33	BT-33	BT-33	BT-34
Symptom	Excessive wind noise	1		3		2
	Water leaks		2	3		1
	Sunroof rattles		4	2	3	1
	Excessive operation noise			2	3	1

The numbers in this table mean checking order.

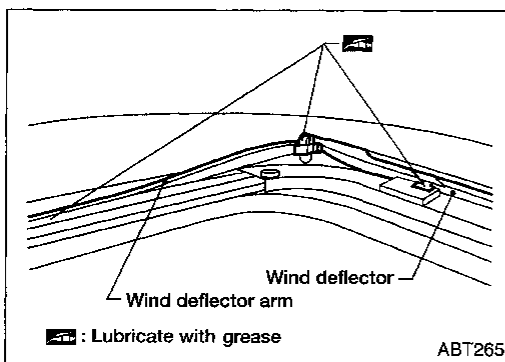

### WIND DEFLECTOR

1. Open lid.
2. Check visually for proper installation.
3. Check to ensure a proper amount of grease has been applied to wind deflector connection points; apply if necessary.
4. Check that wind deflector is properly retracted by hand. If it is not, remove and visually check condition. If wind deflector is damaged, replace with new one. If wind deflector is not damaged, re-install properly.

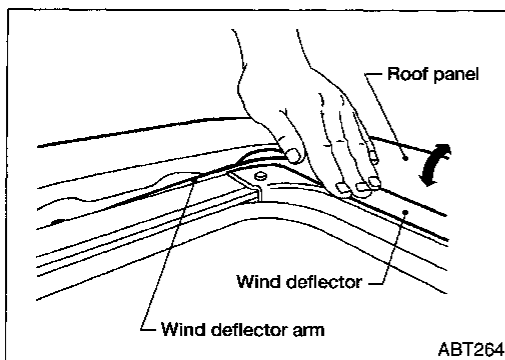



# SUNROOF

## Trouble Diagnoses (Cont'd)

### DRAIN HOSES

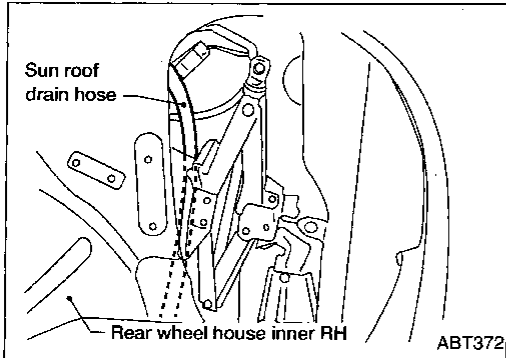
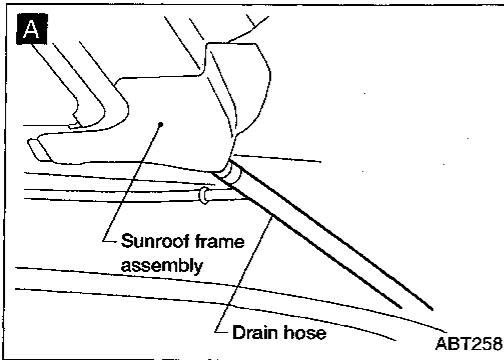

1. Remove headlining to access drain hose connections. (Refer to "REMOVAL — Headlining" in "INTERIOR TRIM", BT-20, for details.)
2. Check visually for proper connections, damage or deterioration. **A** (The figure shows only the front side.)

3. 4 door. If leakage occurs around trunk room, remove trunk room side trim and check connecting area. Check for proper connection, damage.
4. Remove drain hoses and check visually for any damage, cracks, or deterioration.
5. Pour water into drain hoses and find damaged portion.
  - If any damaged portion is found at each step, replace the damaged part.

### WEATHERSTRIP

- In case of leakage around lid, close lid and pour water over lid to find damaged or gap portion.
- If gap is between weatherstrip and roof panel, perform gap adjustment. Refer to procedure on BT-34.
- If gap is between weatherstrip and lid, or if weatherstrip is flattened, damaged or deteriorated, replace lid assembly. (Weatherstrip is not serviceable.)

### LINK AND WIRE ASSEMBLY

#### NOTE:

Before replacing a suspect part, carefully ensure it is the source of noise being experienced.

1. Check link to determine if coating film has peeled off to such an extent that substrate is visible. Check also to determine if link is the source of noise. If it is, replace it.
2. Visually check to determine if a sufficient amount of petroleum jelly has been applied to wire or rail groove. If not, add petroleum jelly as required.
3. Check wire for any damage or deterioration. If damaged, replace wire.

GI

MA

EM

LC

EC

FE

CL

MT

AT

FA

RA

BR

ST

RS

**BT**

HA

EL

IDX

# SUNROOF

## Adjustment

Install motor & limit SW assembly and sunroof rail assembly in the following sequence:

1. Arrange equal lengths of link and wire assemblies on both sides of sunroof opening.
2. Connect sunroof connector to sunroof switch and positive (+) power supply.
3. Set lid assembly to fully closed position **A** by operating CLOSE switch and TILT switch.
4. Fit outer side of lid assembly to the surface of roof on body outer panel.
5. Remove motor, and keep CLOSE switch pressed until motor pinion gear reaches the end of its rotating range.
6. Install motor.
7. Check that motor drive gear fits properly in wires.
8. Press TILT-UP switch to check lid assembly for normal tilting.
9. Check sunroof lid assembly for normal operations (tilt-up, tilt-down, open, and close).

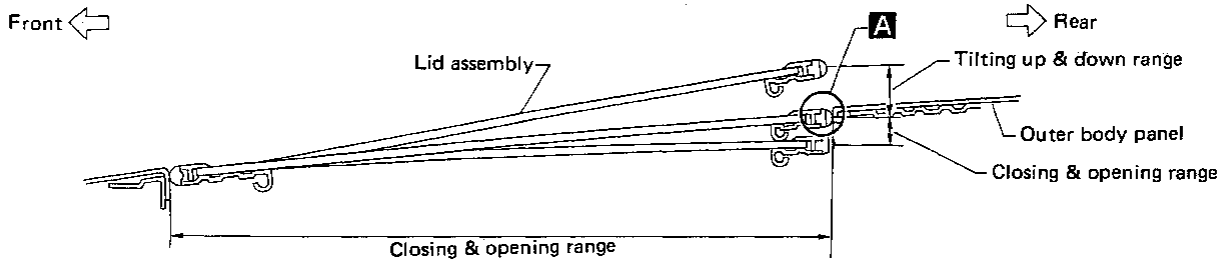

SBF920F

# WINDSHIELD AND WINDOWS

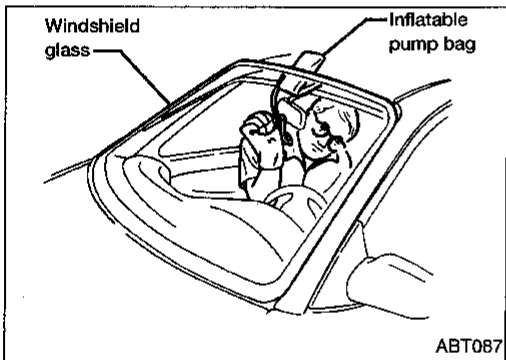
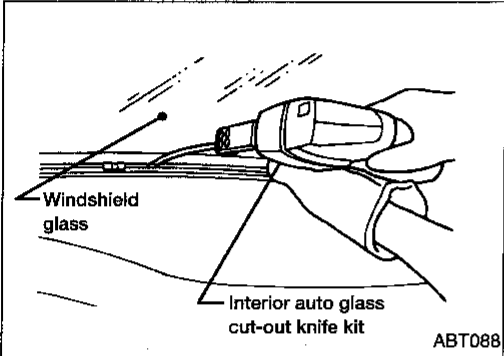
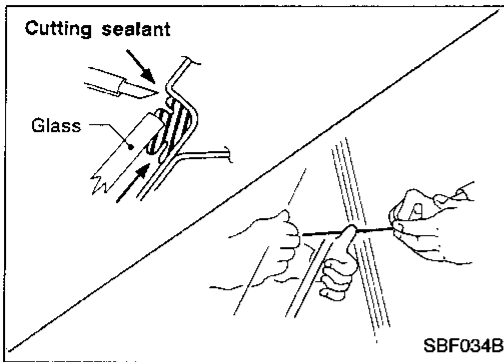

## REMOVAL

After removing moldings, remove glass using piano wire or power cutting tool and an inflatable pump bag.

### WARNING:

When cutting the glass from the vehicle, always wear safety glasses and heavy gloves to help prevent glass splinters from entering your eyes or cutting your hands.

### CAUTION:

- Be careful not to scratch the glass when removing.
- Do not set or stand the glass on its edge. Small chips may develop into cracks.

## INSTALLATION

- Use genuine Nissan Urethane Adhesive Kit or equivalent and follow the instructions furnished with it.
- While the urethane adhesive is curing, open a door window. This will prevent the glass from being forced out by passenger compartment air pressure when a door is closed.
- The molding must be installed securely so that it is in position and leaves no gap.
- Inform the customer that the vehicle should remain stationary until the urethane adhesive has completely cured (preferably 24 hours). Curing time varies with temperature and humidity.

### WARNING:

- Keep heat and open flames away as primers and adhesive are flammable.
- The materials contained in the kit are harmful if swallowed, and may irritate skin and eyes. Avoid contact with the skin and eyes.
- Use in an open, well ventilated location. Avoid breathing the vapors. They can be harmful if inhaled. If affected by vapor inhalation, immediately move to an area with fresh air.
- Driving the vehicle before the urethane adhesive has completely cured may affect the performance of the windshield in case of an accident.

### CAUTION:

- Do not use an adhesive which is past its usable term. Shelf life of this product is limited to six months after the date of manufacture. Carefully adhere to the expiration or manufacture date printed on the box.
- Keep primers and adhesive in a cool, dry place. Ideally, they should be stored in a refrigerator.
- Do not leave primers or adhesive cartridge unattended with their caps open or off.
- The vehicle should not be driven for at least 24 hours or until the urethane adhesive has completely cured. Curing time varies depending on temperature and humidities. The curing time will increase under higher temperatures and lower humidities.

GI

MA

EM

LC

EC

FE

CL

MT

AT

FA

RA

BR

ST

RS

BT

HA

EL

IDX

# WINDSHIELD AND WINDOWS

## Windshield and Rear Window

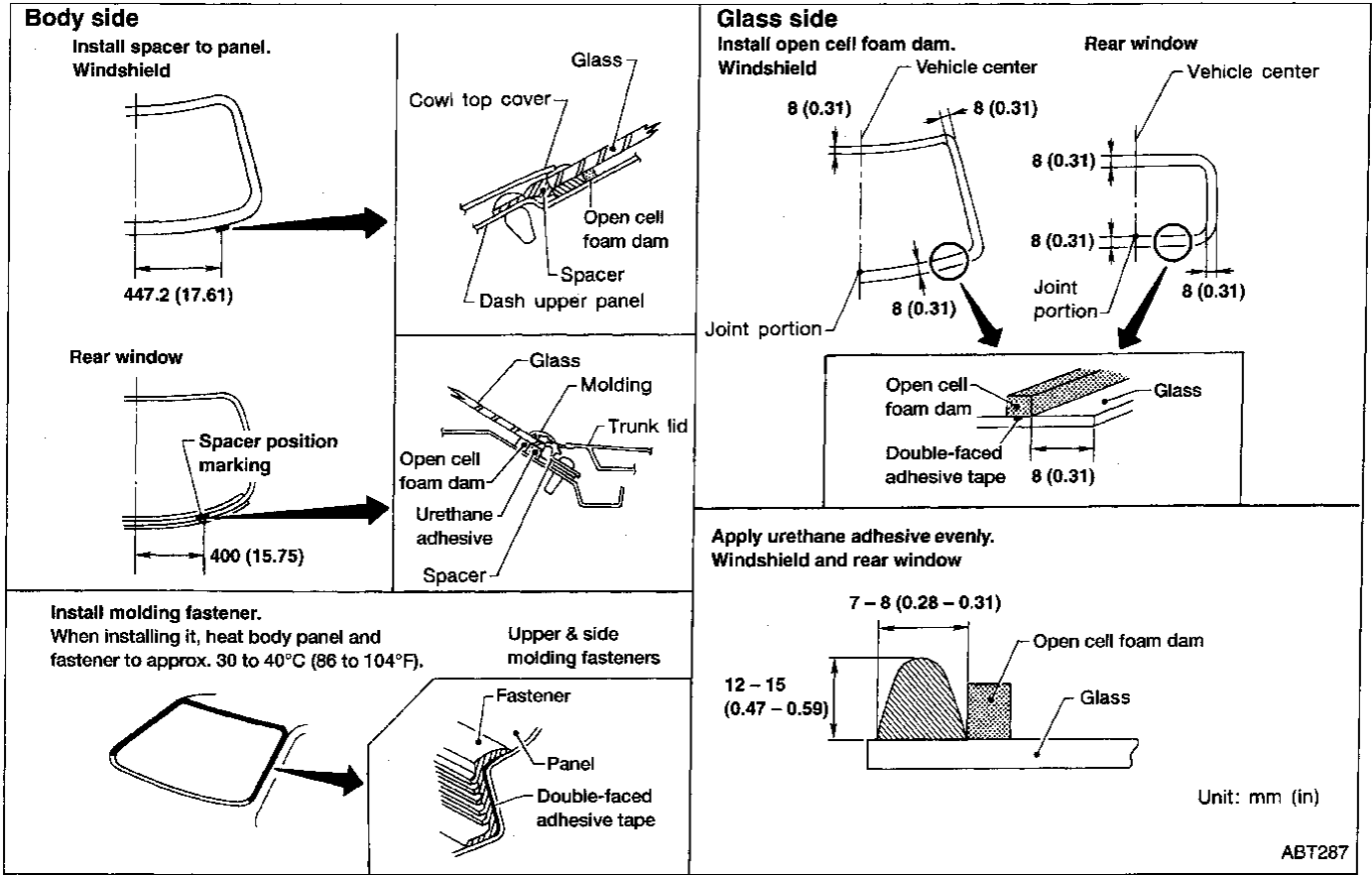

### REPAIRING WATER LEAKS FOR WINDSHIELD

Leaks can be repaired without removing and reinstalling glass.

**If water is leaking between caulking material and body or glass, determine the extent of leakage. This can be determined by applying water while pushing glass outward.**

To stop the leak, apply primer and then sealant to the leak point.

## Quarter Window

### Removal

Remove the rear door trim. For details, refer to BT-18.

Roll the rear window down.

- ① Remove two screws securing rear glass, then remove rear glass.
- ② Remove three screws securing rear door center sash, then remove rear door center sash.
- ③ Remove quarter glass.

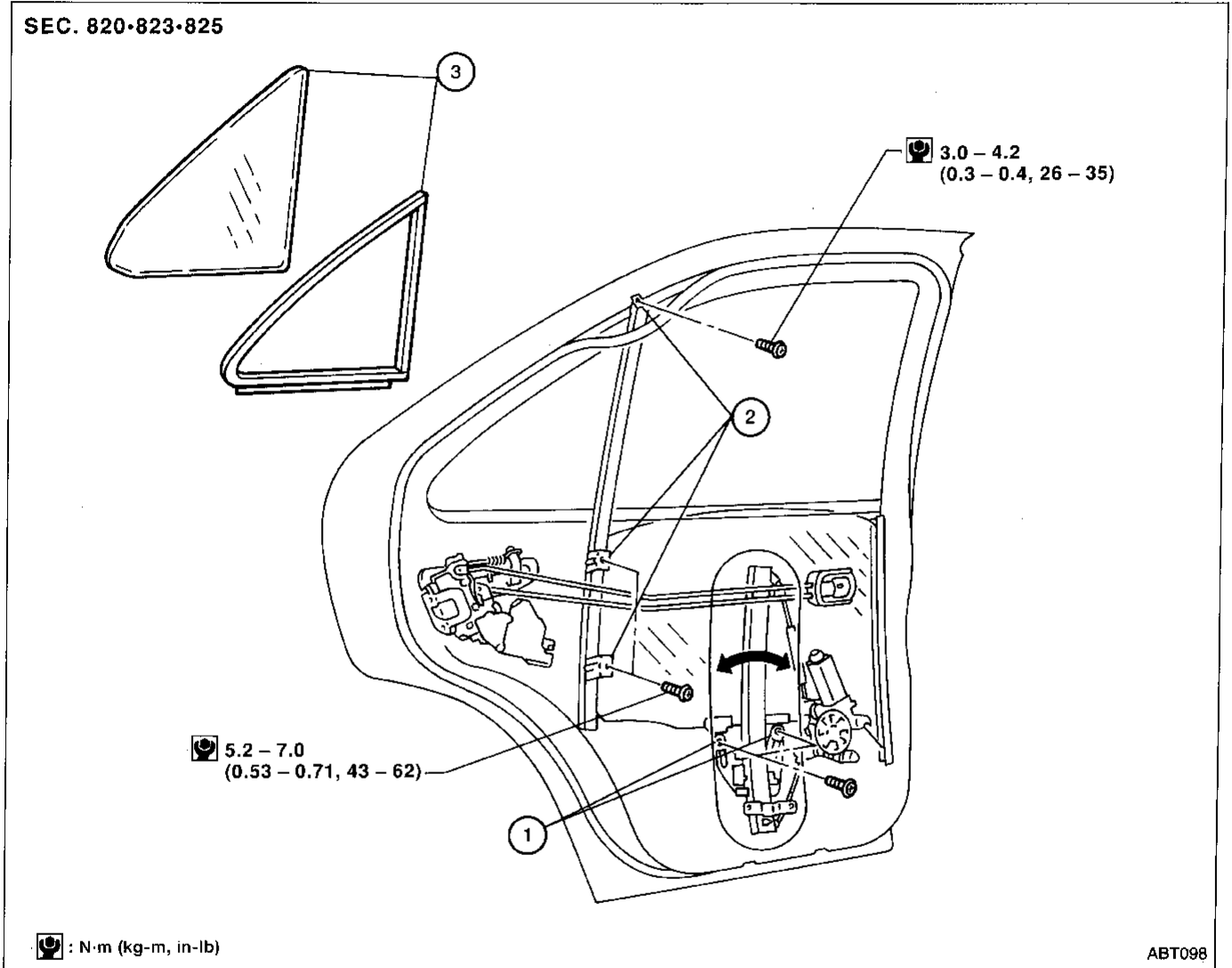

GI

MA

EM

LC

EC

FE

CL

MT

AT

FA

RA

BR

ST

RS

**BT**

HA

EL

IDX

# MIRROR

## Door Mirror

### CAUTION:

Be careful not to scratch door mirror body.

### REMOVAL — Door mirror

Remove door trim. For details, refer to BT-18.

- ① Remove inner cover from front corner of door.
- ② Disconnect door mirror harness connector.
- ③ Remove three bolts securing door mirror assembly.

SEC. 963

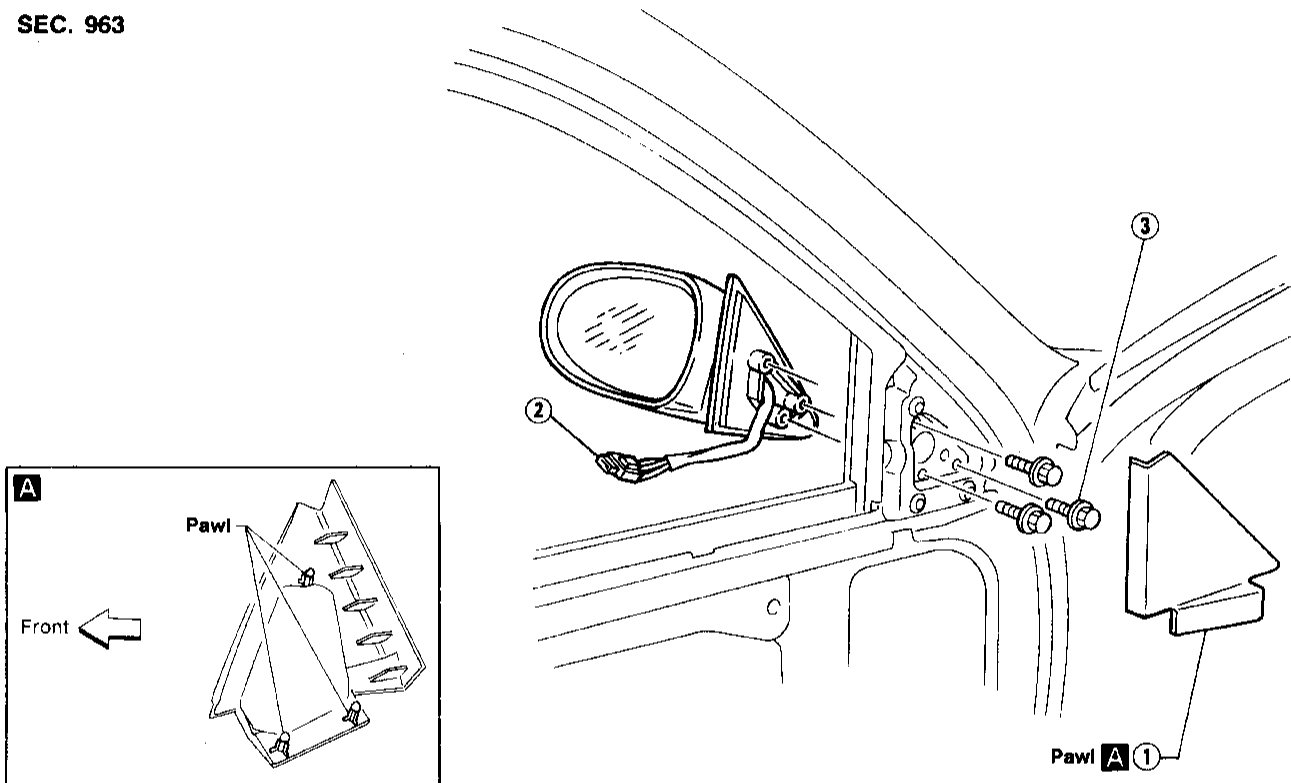

### Mirror glass replacement

#### CAUTION:

Do not exceed specified temperature or time limit. Excess heat or duration may cause damage to the mirror housing.

#### • Removal

1. Use a heat lamp (at least 500 watts) to thoroughly warm the frame edge of the door mirror glass to approximately 70°C (159°F) for three minutes.
2. Insert a stiff blade scraper between the mirror glass and the frame. Pry the glass loose.
3. Remove any remaining adhesive (butyl tape) from the mounting surface on the frame.

#### • Installation

1. Install butyl/adhesive tape (2 pieces) on the frame.
2. Warm the mirror glass frame edge thoroughly with a heat lamp.
3. Position mirror glass on frame. Carefully press on the mirror glass to seat it in place.

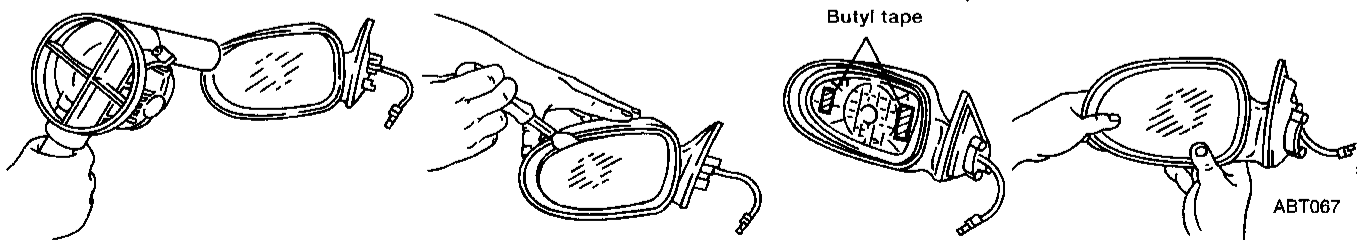

ABT067

# BODY ALIGNMENT

- All dimensions indicated in figures are actual ones.
- When using a tracking gauge, adjust both pointers to equal length. Then check the pointers and gauge itself to make sure there is no free play.
- When a measuring tape is used, check to be sure there is no elongation, twisting or bending.
- Measurements should be taken at the center of the mounting holes.
- An asterisk (\*) indicates the measuring point value is the same on both sides.
- The coordinates of the measurement points are the distances measured from the standard line of "X", "Y" and "Z".

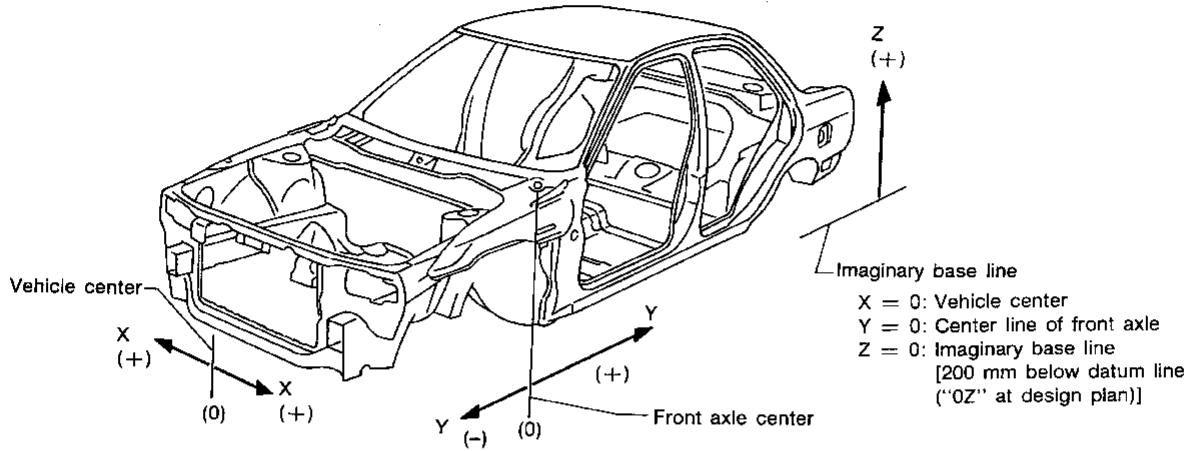

SBF874GC

## Engine Compartment

### MEASUREMENT

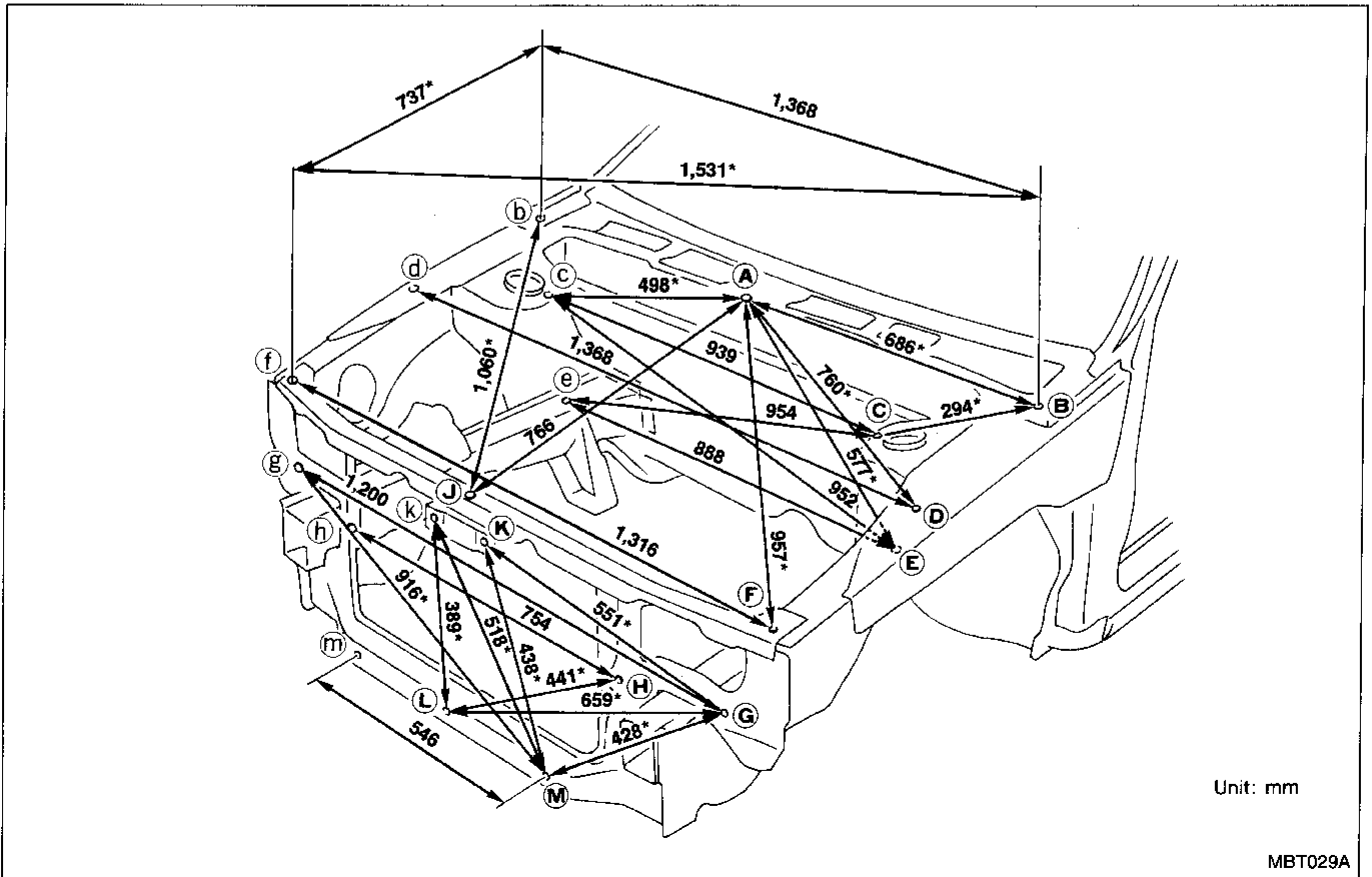

# BODY ALIGNMENT

## Engine Compartment (Cont'd)

### MEASUREMENT POINTS

Unit: mm

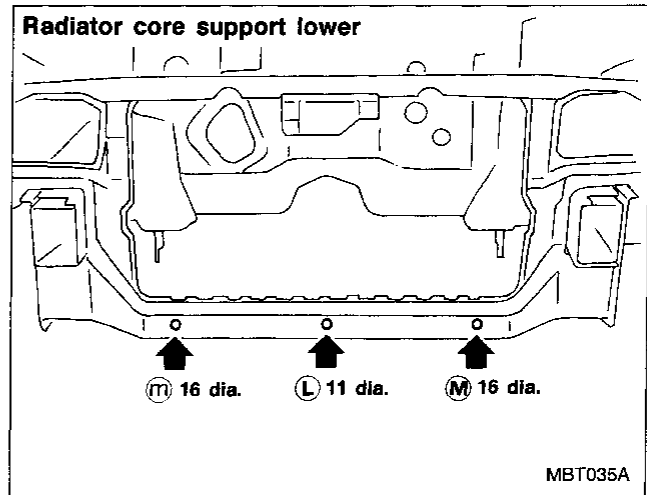
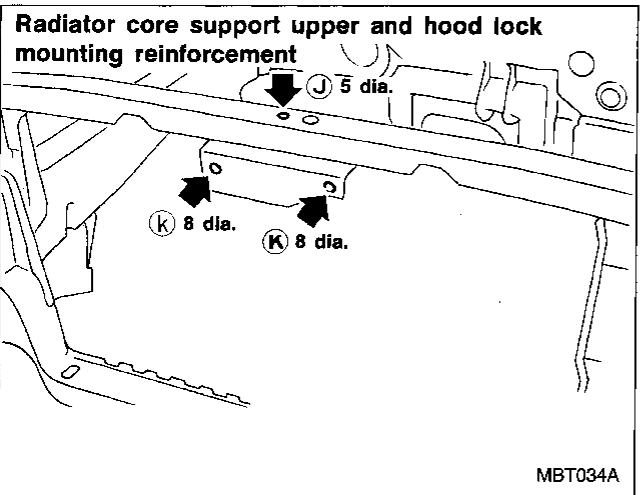
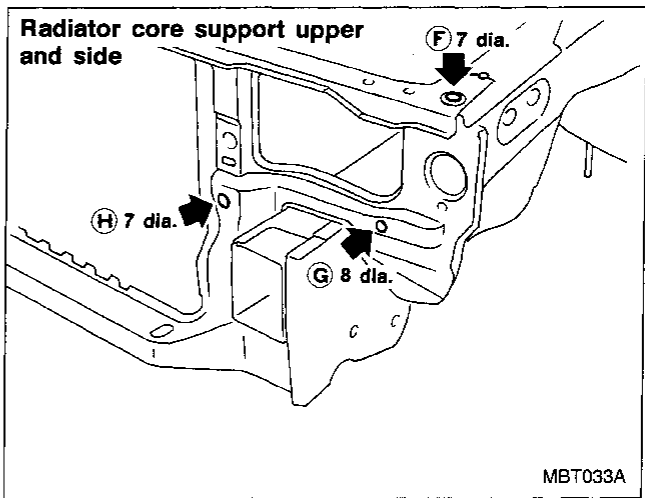
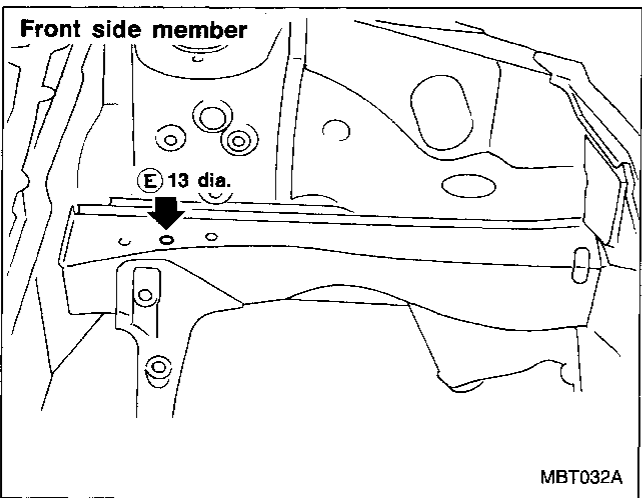
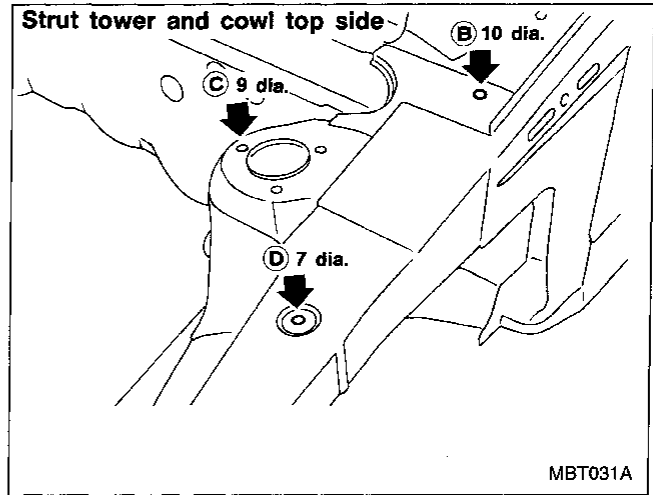
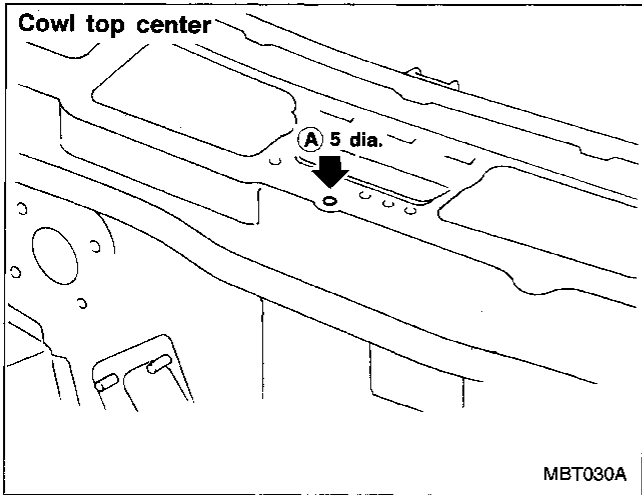



# BODY ALIGNMENT

## Underbody

### MEASUREMENT

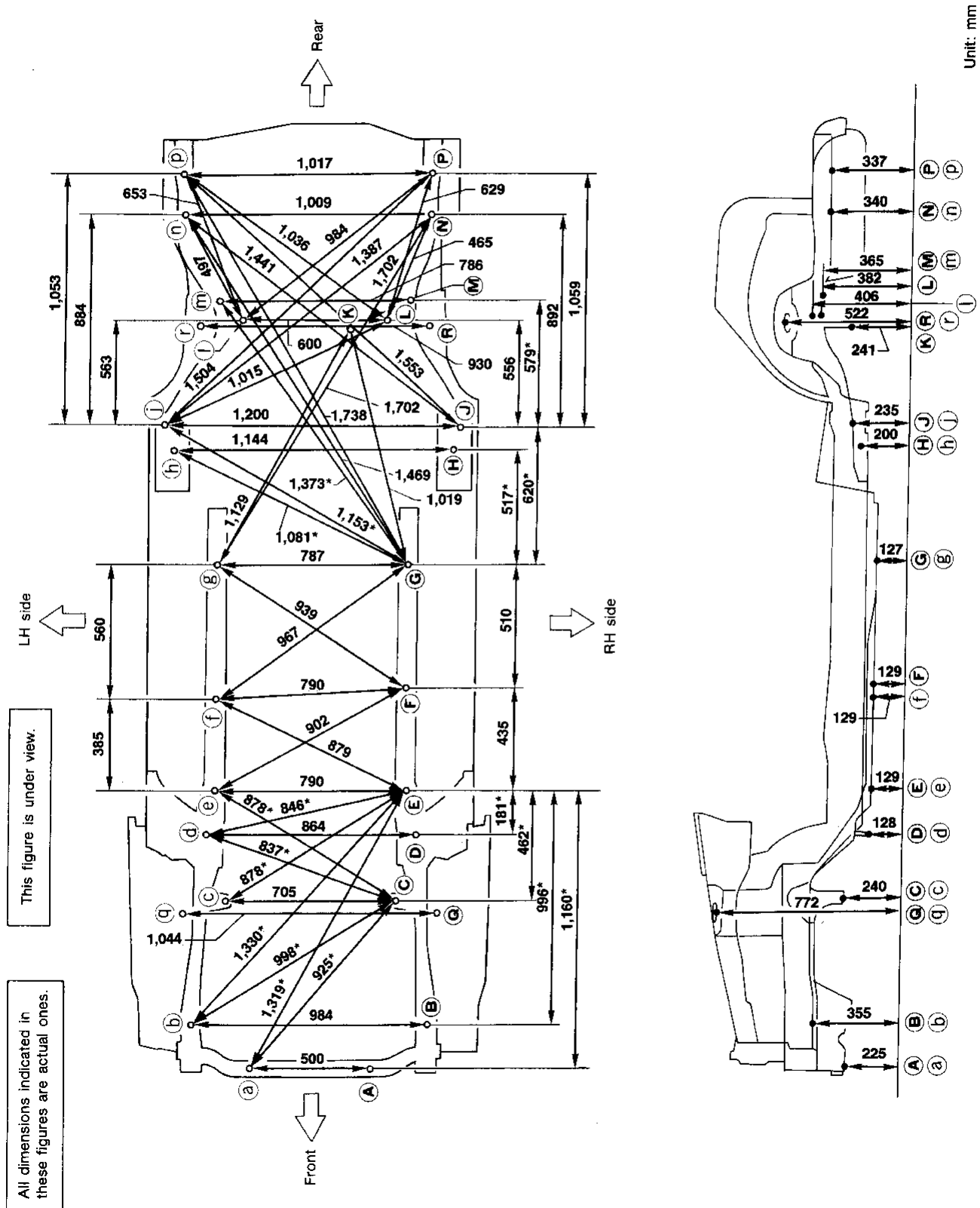

# BODY ALIGNMENT

## Underbody (Cont'd)

### MEASUREMENT POINTS

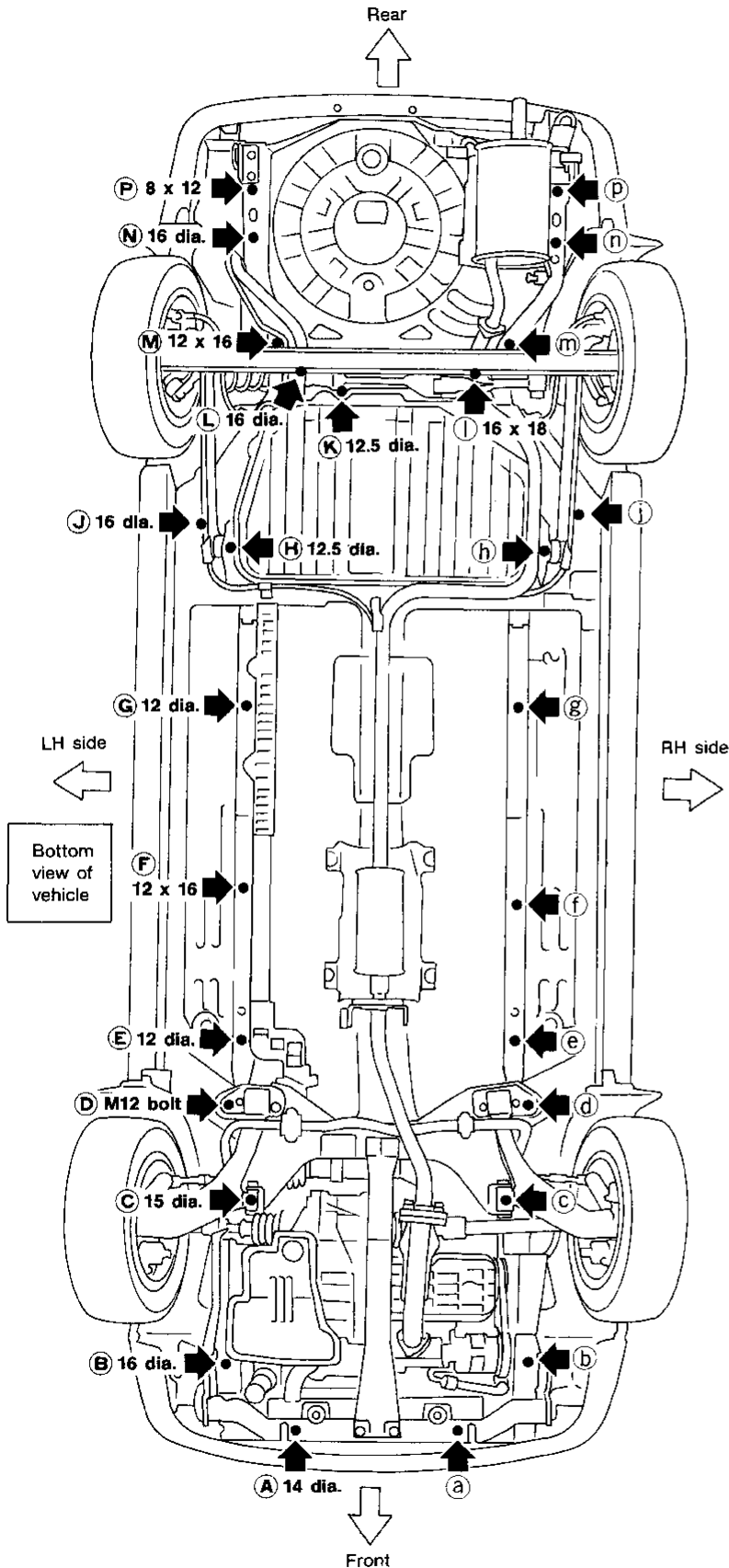

Front coordinates:	Rear coordinates:
(A), (a)	(G), (g)
X : 250	X : 393.5
Y : -632	Y : 1,460
Z : 224.8	Z : 126.9
(B), (b)	(H), (h)
X : 492	X : 572
Y : -450	Y : 1,940
Z : 355	Z : 200
(C), (c)	(J), (j)
X : 352.7	X : 600
Y : 69	Y : 2,035
Z : 240	Z : 235.2
(D), (d)	(K)
X : 432	X : 150
Y : 338	Y : 2,487.9
Z : 128	Z : 241
(E), (e)	(L)
X : 395	X : 300
Y : 515	Y : 2,480
Z : 129.2	Z : 381.8
(F)	(I)
X : 395	X : 300
Y : 950	Y : 2,480
Z : 129.2	Z : 405.8
(f)	(M), (m)
X : 395	X : 393
Y : 900	Y : 2,560
Z : 129.2	Z : 365
	(N)
	X : 470
	Y : 2,911
	Z : 339.6
	(n)
	X : 539
	Y : 2,911
	Z : 339.6
	(P)
	X : 475
	Y : 3,082
	Z : 335.8
	(p)
	X : 542
	Y : 3,082
	Z : 335.8

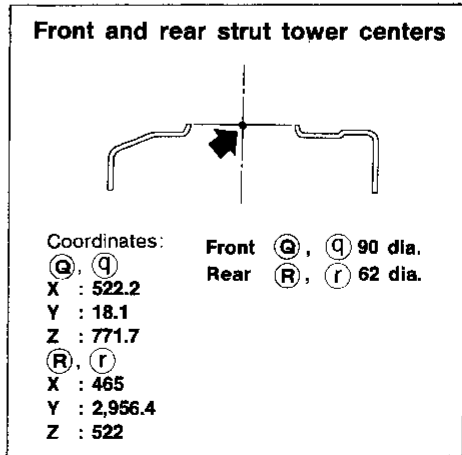

Unit: mm